

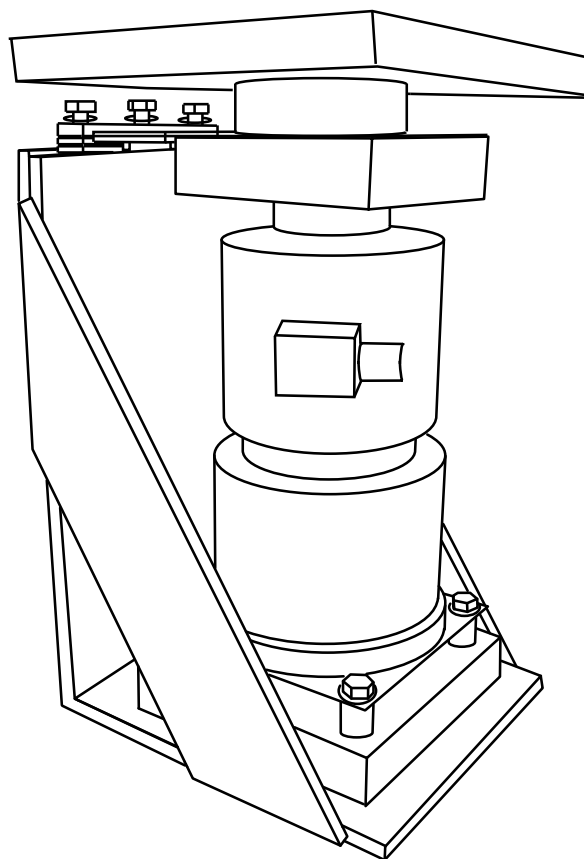

# A.A.R. Combination Railroad Track / MTS Scale

**Model(s): 12-1492  
12-1493  
12-1494  
12-1495  
12-1496**





# Amendment Record

A. A.R. Railroad  
Combination MTS Scale  
Model(s): 12-1492,12-1493,12-1494,12-1495  
50538

Manufactured by Fairbanks Scales Inc.  
821 Locust  
Kansas City, Missouri 64106

Created	9/99	
Issue #1	9/99	Software Update.
Issue #2	12/01	Update arrangement/flow.
Issue #3	10/03	Updated Information and Drawings
Revision 4	05/08	Updated Load Cell Assembly image and corresponding parts information; Added special Load Cell Appendix with parts list
Revision 5	05/08	Updated Information and Drawings, per Notes from Engineering Dept.



# Table of Contents

## Section 1: General Information

1-A: Introduction & General Description	Page 9
1-B: Specifications	Page 9
1-C: Rails & Anti-Creep Devices	Page 10
1-D: Regulations from the AAR Scale Handbook	Page 11
1-E: Foundation Construction & Installation	Page 13
1-D: Ground Rods	Page 14
1-E: Load Cell Base Plates	Page 14
1-D: Check Stands	Page 15
1-E: Weighbridge	Page 15
1-F: Deck Construction	Page 15
1-G: Load Cell Flexure Assembly	Page 16

## Section 2: Installation

2-A: General Service Policy	Page 17
2-B: Pre-Installation checkout	Page 17
2-C: Unpacking	Page 18
2-D: Safety	Page 18
2-E: Recommended Installation Sequence	Page 19
2-F: Foundation Inspection	Page 20
2-G: Foundation Inspection Check List	Page 23
2-H: Base Plate Assemblies	Page 23
2-I: Check Stands	Page 23
2-J: Weighbridge Steel	Page 24
2-K: Weighbridge Hardware	Page 24
2-L: Assembling Weighbridge Sections	Page 25
2-M: Installing Weighbridge Sections	Page 27
2-N: Load Cell Flexure Assembly	Page 29
2-O: Adjusting Elevation	Page 31
2-P: Leveling Load Cell Flexure Assemblies	Page 33
2-Q: Grouting Load Cell Baseplates	Page 36
2-R: Checkrods	Page 39
2-S: Check Rod Adjustment	Page 41
2-T: Deck Forming	Page 42
2-U: Junction Boxes	Page 47
2-V: Grounding	Page 47

## Section 3: Service & Maintenance

3-A: Basic Maintenance

Page 49

## Section 4: Parts list

Parts List

Page 50

## Appendix

Appendix I:	Recommended Tools & Equipment	Page 53
Appendix II:	Required at Jobsite	Page 54
Appendix III:	Materials	Page 54
Appendix IV:	Torque Values Chart	Page 55
Appendix V:	Tolerances	Page 55
Appendix VI:	Load Cell Specifications	Page 55
Appendix VII:	Concrete & Sump Testing	Page 56
Appendix VIII:	About the AAR, AREMA, & AREA	Page 57
Appendix X:	Special Product Applications -- Short Load Cell Assembly	Page 58

## Index of Illustrations:

50538-1	Deck with recessed rail	Page 6
50538-2	Anti-Creep Device	Page 7
50538-3	Rail Miter Cut Gaps	Page 7
50538-4	Ground Rod Locations	Page 11, 47
50538-5	Load Cell Flexure Assembly	Page 13
50538-3A	Foundation Inspection Check list	Page 18
50538-6	Base Plate Installation	Page 19
50538-7	Weighbridge Steel: Assembled Section	Page 20
50538-7A	Weighbridge Steel: Component Identification	Page 20
50538-7B	Weighbridge Hardware	Page 21
50538-8	Weighbridge Steel Layout	Page 22
50538-9	Weighbridge Steel Assembling	Page 22
50538-10	Installing Weighbridge Checkbracket	Page 22
50538-11	Installing Stiffener Plate & Top Bearing Plate Assy	Page 23
50538-12	Centering Weighbridge Sections	Page 24
50538-13	Centering Main Beams	Page 25
50538-14	Load Cell Flexure Assembly; Exploded View	Page 26
50538-15	Load Cell Flexure Assembly Orientation	Page 27
50538-16	Load Cell Flexure Assembly; Centering	Page 28
50538-17	Leveling End Section	Page 29
50538-18	Leveling Middle Sections	Page 29
50538-19	Load Cell Flexure Assembly; Leveling	Page 30
50538-20	Load Cell Locations	Page 31
50538-21	Base Plate Forming & Grouting	Page 34
50538-22	Base Plate Forming & Grouting	Page 35
50538-23	Base Plate Forming & Grouting: Sloping Grout	Page 35
50538-24	Weighbridge Check Stands	Page 36
50538-25	Check Rod Washer Sets	Page 36
50538-26	Pier Check Stands	Page 37
50538-27	Check Stands: Leveling	Page 37
50538-28	Check Rods: Adjusting	Page 40
50538-29	Deck with recessed rail Pocket	Page 41
50538-30	Deck Forming: Hex Nut Spacers	Page 41
50538-31	Deck Forming: Placing and Welding Deck Coping	Page 42
50538-32	Deck Forming: Placing and Welding Deck Coping	Page 42
50538-33	Deck Forming: 12 Corner Junctures	Page 43
50538-34	Deck Forming: Deck Coping at Rails	Page 43
50538-35	Deck Forming: Installing Corrugation	Page 43
50538-36	Deck Forming: Installing Corrugation	Page 44
50538-37	Deck Forming: Installing Rebar	Page 44
50538-38	Deck Forming: Installing Bituminous Mastic	Page 45
50538-39	Deck Forming: Steel Plates at End of Rail Pockets	Page 45
50538-40	Junction Boxes	Page 46
50538-41	Grounding	Page 47
50538-42	Parts List	Page 50
50538-14	Previous Load Cell Revision -- Before 1992	Page 58



## **A.A.R. Combination Railroad Track / MTS Scale**

NOTE: This manual is intended to compliment and be used in conjunction with the Certified Prints provided by FAIRBANKS SCALES. Installation should be attempted only with the presence and guidance of experienced personnel who are fully familiar with the assembly of these scales. Please read this Bulletin in its entirety BEFORE setting scale hardware.

### **SECTION 1-A: Introduction & General Description:**

The Fairbanks Model **A.A.R.\*** Combination Railroad Track / Motor Truck Scale is fully electronic in design, and utilizes eight 200,000 lb capacity compression loadcells that are constructed of Stainless Steel and hermetically sealed for protection against moisture. The four (4) section Scale is pit installed, and is offered in five (5) different standard Models that provide a sectional capacity of 180 Tons, and a total capacity of 360 Tons.

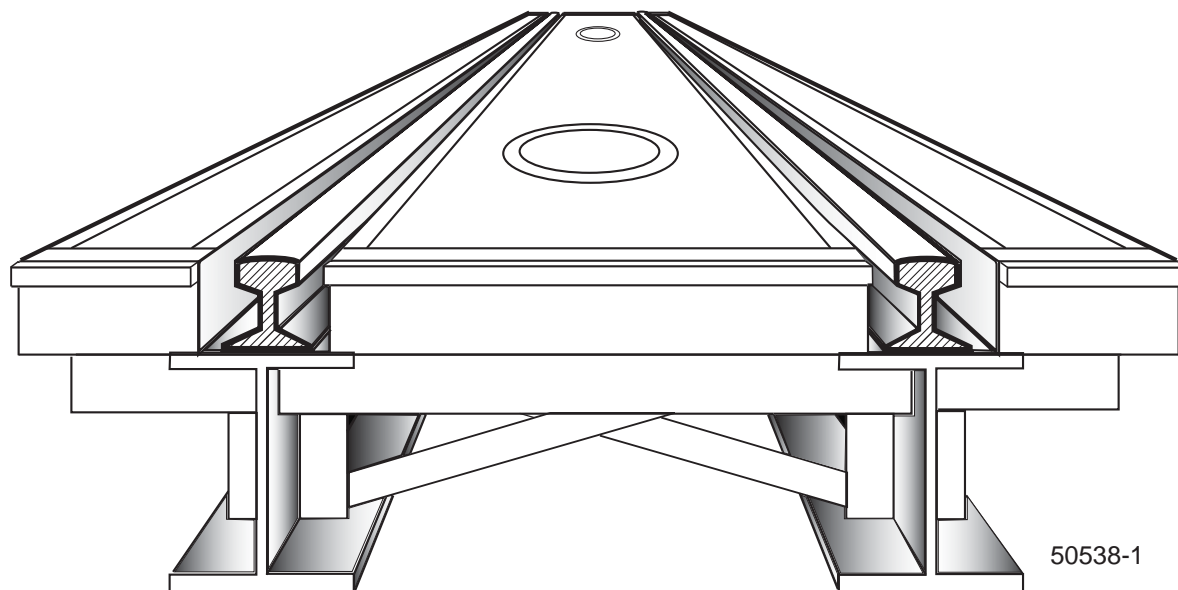

The full platform of the scale is arranged to accommodate a railroad car or a motor truck for weighing. The track rails are installed in a recessed rail pocket below grade, thus presenting no obstruction to rubber tires. Interface to a Fairbanks 2500 Series Indicator with INTA-LOGIX technology is standard.

### **1-B: Specifications:**

Product #	Description	Shipping Weight
90840	Model 1492: 60' X 10' Platform	36,500 lb.
90841	Model 1493 66' X 10' Platform	41,700 lb.
90842	Model 1494 70' X 10' Platform	48,700 lb.
90843	Model 1495 72' X 10' Platform	49,900 lb.
99179	Model 1496 80' X 10' Platform	60,900 lb.

\* **The Association of American Railroads (AAR)**

## 1-C: Rails & Anti-Creep Devices

The Scale is designed to accept a 115 lb. rail with Foster #62 rail clip. The approach rails and Scale Weigh Rail should be the same weight. The approach anchor bolts, approach rail plates, rail clips, and anti - creep devices are all optional items. They can be supplied by Fairbanks Scales when ordered as accessories, otherwise they are not supplied.

Positive means must be provided by others to prevent the creeping of the approach rails and to maintain a clearance which shall be not less than 1/8 inches or more than 5/8 inches between the approach rails and the weigh rails. Switch points are highly recommended for this purpose. A minimum of seventy five (75) feet of tangent track at each approach is required by the A.A.R.

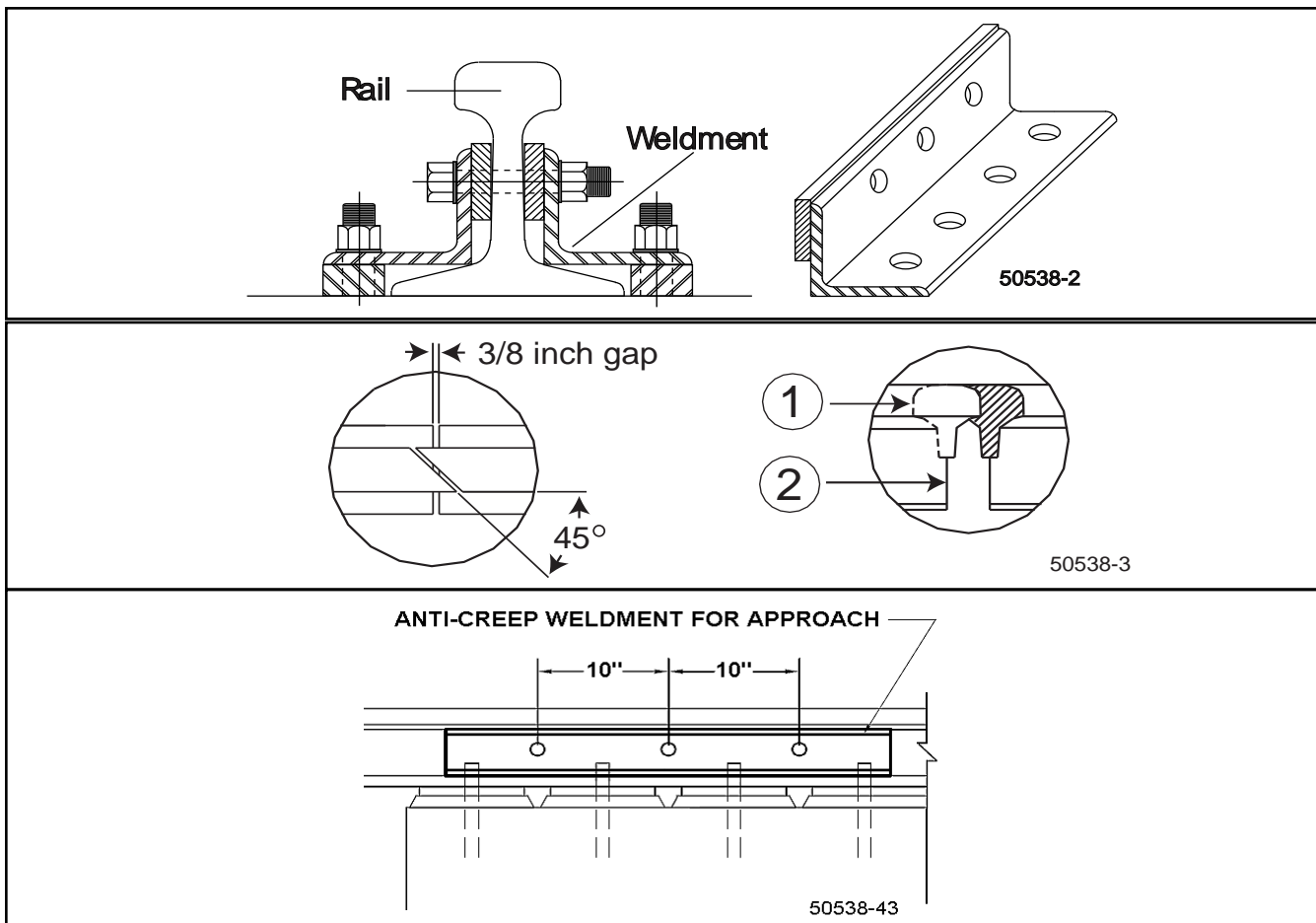

Anti-creep devices are constructed of angle iron with a flat iron weldment to fit to the rail as shown above, The rail is side drilled through its web and bolted to the anti - creep device, effectively securing it from any movement.

The AAR Scale Specifications state that the rail on the approach and the weighbridge shall be properly anchored to prevent creeping of the rails. This is done in order to maintain the proper gap between the approach rail and the weighrail.

Rails should be miter cut at the ends of the weighrails and approach rails to assure a smooth transfer of wheels in order to reduce impact loading to the scale.

**NOTE:** It is *strongly recommended* that any anti-creep device(s) be installed by qualified rail-road maintenance and repair service personnel.

## **1-D: Regulations:**

This Scale is designed and manufactured in accordance with regulations established by Handbook 44 as adopted by the National Conference of Weights and Measures (NCWM), the Association of American Railroads (AAR), and the National Institute of Standards and Technology (NIST). If the Scale is intended to provide weights to the serving railroad for the purpose of revenue, it shall be installed, repaired, tested, and maintained in accordance with the Association of American Railroads Scale Handbook, which contains the rules and specifications for the construction and maintenance of track scales for the weighing of railroad vehicles.

### **Excerpts from the Association of American Railroads Scale Handbook**

**Location:** Scale shall be so located that an adequate foundation and at least 75 feet of tangent track at each approach to the weighrails can be provided.

**Elevation:** In areas with poor drainage, the scale shall be raised to such an elevation that drainage of the surface water shall be away from it. Means shall be provided to prevent accumulation of water at the scale site. Solutions for saturated areas with poor drainage shall be determined by a competent soils engineer.

**Drainage:** The pit floor shall be pitched to a common point for drainage and shall be smooth and free from pockets in which water may stand. If the pit floor is below substrate water level, the pit shall be drained from its lowest point into a sump adequately equipped with automatic means for removal of water as it collects.

**Footing or Piers for loadcells:** Concrete footings or piers supporting load cell base plates shall not be less than 18 inches thick. Their tops shall be above the floor a sufficient distance to prevent the accumulation of water around or under the base plates.

**Pit floor:** The floor of the pit may be a mat of concrete approximately as thick as that required to support the load cell base plates or, if local conditions permit, the thickness may be reduced to no less than 6 inches.

**Ventilation:** All scale pits shall be ventilated to meet the needs of each particular case to minimize the relative humidity in the pit and to retard corrosion of scale parts and structural steel.

**Entrance to the Scale Pit:** Suitable access to the Scale pit shall be provided. The entrance shall be closed by a suitable closure fastened to prevent the entry of unauthorized persons.  
AAR Scale Handbook

**Safety Piers:** Suitable piers, columns, or other supports should be provided to prevent excessive drop of the girders if there should be a failure of other Scale parts. Clearance should be maintained at full scale capacity.

**Bearing Pressures Under Foundations:** The bearing areas of the foundation footings shall be such that the pressure under the footings will not exceed:

- For fine sand and clay ..... 4,000 lb. per square foot
- For coarse sand or hard clay ..... 6,000 LB per square foot
- For boulders or solid rock ..... 20,000 LB per square foot

If the soil does not have a bearing capacity of at least 4,000 pounds per square foot, and its bearing capacity cannot be increased by drainage, stabilization, or other means, pile foundations shall be provided. Careful soil exploration, including borings, is always desirable.

**Leveling:** Load cell assemblies shall be raised or lowered, as required, by means of leveling screws, shims, or other methods to bring the weighbridge into level transversely and on grade longitudinally. After leveling the load cell baseplates, to a tolerance of not more than 1/64" per foot, they shall be grouted as required.

**Scale House Design:** Except where the indicating elements are mounted in a separate building, a Scale house large enough to install, observe and service the indicating elements shall be provided. It should have windows of sufficient size and so located as to give the weigher an unobstructed view of the Scale deck and approaching cars or trucks.

Where a special scale house is required, a suitable and substantial building shall be provided. To insure proper operation of the indicator and/or recorder, the house shall be equipped with proper environmental control.

**Scale House Location:** The lateral clearance between the Scale house and centerline of Scale or any track shall not be less than 8 feet, unless otherwise required by law, or the serving railroad.

Indicator - Recorder Shelf: If a shelf is required for mounting the indicator and/or recorder, it shall be so located as to provide for ease of operation without obscuring the weigher's view of the Scale deck and approaching cars or trucks. The shelf must not limit ready access to the instrument for maintenance purposes.

**Power Source** The power source of the electronic instrumentation and load cell circuitry shall conform to the following:

Voltage - 115 v AC +/- 10 v

Frequency - 60 Hz, +/- 0.25 Hz

The power source must be reasonably free from harmonics and electrical transients.

Fusing shall be provided at 15 amp unless otherwise specified by the manufacturer.

The power source shall be a separate circuit back to the distribution transformer.

One side of the 115 v power source shall be at a ground potential.

Power surge protection shall be provided for load cells and instrumentation circuit.

Adequate protection of shielding should be provided to eliminate radio frequency and electromagnetic interference. The scale must satisfy the tolerance requirements when the scale equipment is subjected to RFI and EMI influences.

## **Cabling:**

All cabling between loadcells, junction boxes, and electronic instrumentation shall conform to the following:

All cable shields shall be interconnected and carried to a single ground. This should be a separate ground from the power source ground and be provided for the loadcells and instrumentation circuits only. It should be a copper rod which, when possible, is driven to the depth of the water table.

The connection between the ground rod and the common ground point of the load cell and instrumentation circuits shall be made with copper wire, or the equivalent, of No. 10 gauge or larger.

All cable shields in the load cell circuits shall be grounded at one end only.

Homerun cables shall be physically separate from power cables and never run in the same conduit system.

**(NOTE: A 24 inch to 36 inch separation is required by Fairbanks Scales)**

All cable connections, junction boxes, etc., in the load cell circuits shall be properly protected against the effects of moisture.

All multi - conductor cabling shall be color - coded, or provided with other means of identification of the individual conductors.

## **1-E: Foundation Construction & Installation**

Use only certified prints that are marked for the particular installation, customer, and scale.

All the dimensions indicated on the certified prints must be rigidly and faithfully followed during all phases of construction. There is very little tolerance for misplacements and mistakes. Pier heights are especially critical as there must be enough space for finishing grout under all stands (per certified drawings) while rails on the scale weighbridge and approach rail must be absolutely level.

Placement of foundation bolts is absolutely critical to the successful installation of the scale. The use of a template or form that matches the design called for can be used. Foundation bolts must NOT be installed at an angle, too deep, or too shallow. Very close tolerances must be met on all aspects of pit construction.

### **1-D: Ground Rods:**

Ground rods are essential in providing protection to the electronic components and loadcells from both lightning surges and static discharges. Pit ground rods shall be tied to the foundations steel reinforcement rod (rebar) prior to pouring, and shall protrude 4 inches above the pit floor.

Ground rods for approach rails shall be installed in the approach rail cut-outs and tied to the rebar assembly. There are five (5) rods with the locations specified as below:

- 1 ground rod at each end, in the approach rail-cuts, for approach rail grounding
- 1 ground rod at each end, in the pit, for steel weighbridge grounding
- 1 ground rod at the pit load cell conduit location for the pit power supply

The following drawing shows correct placement of ground rods.

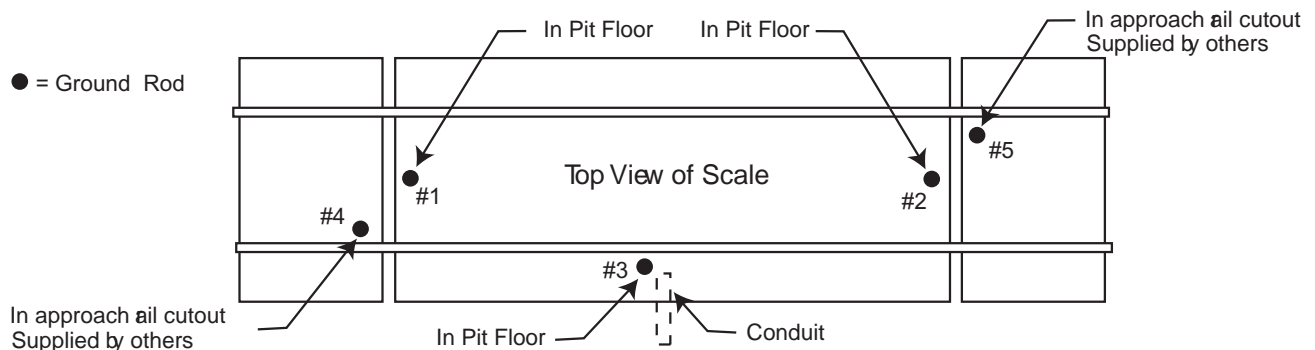

50538-4

### **1-E: Load cell Base Plates:**

The Load cell base plates are the foundation upon which the scale structure rests, and their level, accurate position is basic to the entire structure. Base plates must be installed at proper height and in the same plane. All base plates must be level within 1/64" per foot. All pier bolts must have enough height to allow vertical adjustment of the base plate's, but not so high as to interfere or to have insufficient depth into the pier.

### **1-D: Check Stands:**

Check rods allow for vertical movement in order to transfer weight force to the load cells but they do not allow for lateral or side movement. Checking stands must be level and on the same plane. All check rods must be level within 1/100" per foot when weighbridge is at correct elevation. Grouting the check stands MUST NOT take place until the load cell base plates are adjusted to their final height.

### **1-E: Weighbridge:**

The weighbridge supports the loads applied to it, and transfers that weight to the load cells. Properly installed, this transfer allows the load to be shared by all cells and keeps loading in a vertical direction. For both safety and expediency, it is recommended to assemble the weighbridge steel in sections outside of the pit, then setting the assembled sections into the pit one at a time with a suitable capacity crane.

The weighbridge must be square and the main girders must be vertically plumb so that the bottoms of the main girders are level. Do NOT weld the "X" bracing at the ends of the weighbridge or use impact wrench on steel structure bolts until girders are in place and are plumb.

Main beams must be joined at sections so that the top flanges are level to accommodate the track rails with full contact support without shimming. Due to steel manufacturing tolerances, the height of the main beams may be slightly unequal making the bottom flanges uneven. If shims are required, place between the stiffener plate and the main girder. Full contact shimming is required for stiffener plates. Shims are not supplied with the scale hardware. The resulting upper stiffener plate and top bearing plate must be level within 1/64" per foot.

### **1-F: Deck Construction:**

The construction of the deck will cover the areas alongside and in-between the main beams and Rails, and will provide a custom fitted concrete deck for motor truck and vehicle weighing.

All concrete workmanship shall be performed in accordance with the best practice as described by the American Concrete Institute. The recommended slump is four to six inches (4" to 6").

Allow concrete to cure thoroughly. Do not use, or subject the deck to any traffic until the concrete has attained its ultimate compressive strength of 3000 psi after 28 days.

The steel supplied for the deck construction is precut at the factory to fit an exact dimension pit, as indicated on the prints.

**1-G: Load Cell Flexure Assembly:**

The Load cell flexure assemblies maintain the load cells in a vertical position. In application, the design uses a 200,000 lb capacity compression load cell mounted in a support assembly. The support assembly contains an upper flexure assembly protected by a wear plate, and weight(s) applied to the scale are transferred to them from the top bearing plate assembly.

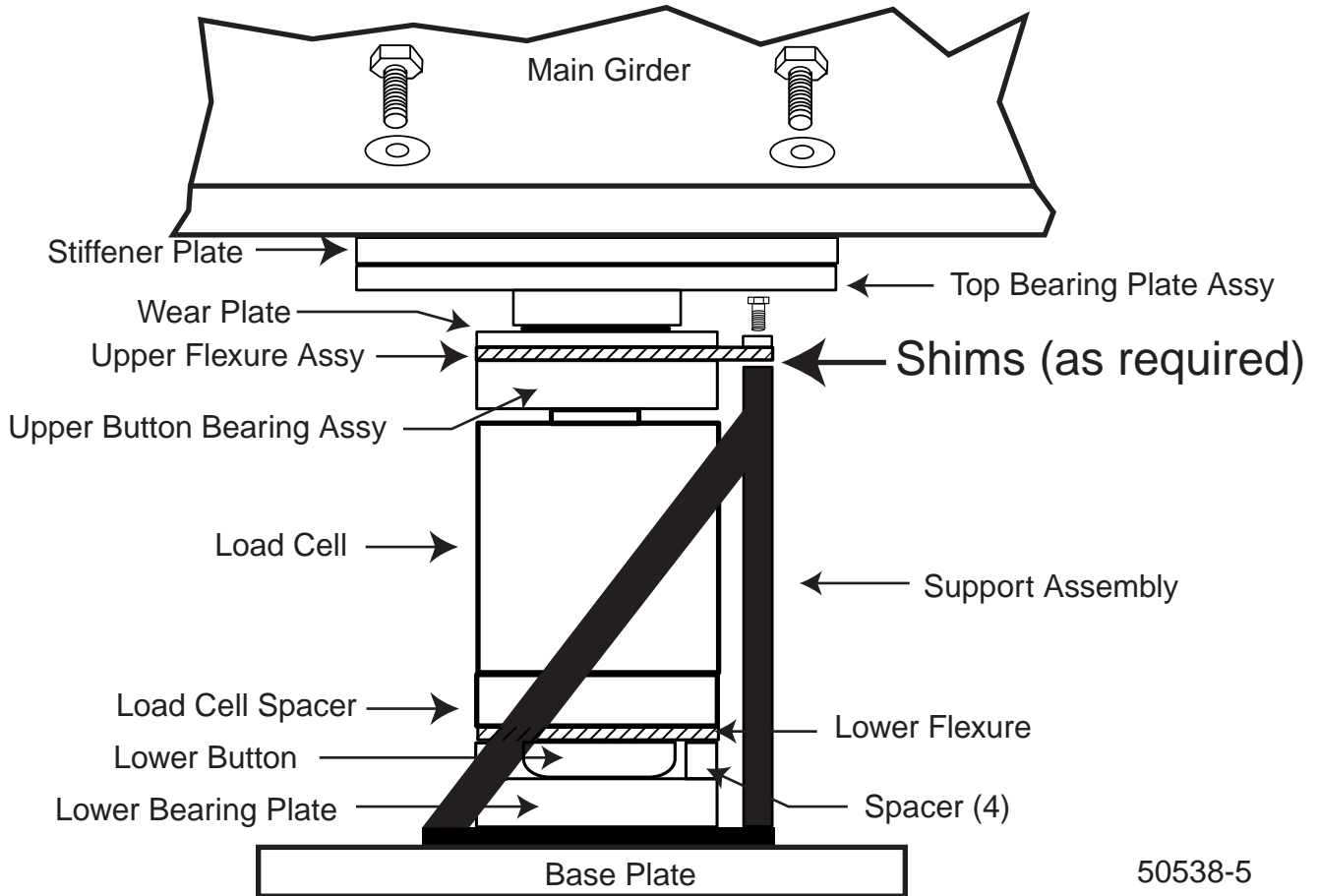

The flexure assembly isolates any lateral movement of the main girder from the top of the load cell. This arrangement allows the cell to remain vertical under all loading conditions, and to minimize the side-load effects of thermal expansion and contraction of the weighbridge.

## **Section 2: Installation:**

### **2-A: General Service Policy**

Prior to installation, it must be verified that the equipment will satisfy the customer's requirements as supplied, and as described in this manual. If the equipment cannot satisfy the application and the application cannot be modified to meet the design parameters of the equipment, the installation should not be attempted.

#### **Overview:**

1. These instructions apply to the Scale Platform only; installation procedures for instrumentation, printers and other peripherals are given in manuals specifically provided for those units. The instructions include a pre-installation checkout, which must be performed before the installation.

2. All electronic and mechanical calibrations and or adjustments required to make this equipment perform to accuracy and operational specifications are considered to be part of the installation, and are included in the installation charge. Only those charges which are incurred as a result of the equipment's inability to be adjusted or calibrated to performance specifications may be charged to warranty.

3. Absolutely no physical or electrical modifications are to be made to this equipment. Electrical connections other than those specified may not be performed, and no physical alterations (mounting holes, etc.) are allowed.

4. The installing technician is responsible to make certain that personnel are fully trained and familiar with the capabilities and limitations of the equipment before the installation is considered complete.

### **2-B: Pre-Installation Checklist:**

The following points should be checked and discussed with the Area Sales Manager and/or customer, if necessary, before the technician goes to the site to install the equipment.

1. Has the customer's application been checked to make certain that it is within the capabilities and design parameters of the equipment?

2. If the installation will disrupt the customer's normal operations, is he aware and has he made arrangements?

3. Is properly-grounded power available at the installation location?

4. Will the equipment operator(s) be available for training?

5. Has the service technician thoroughly reviewed the installation procedures?

6. Has the service technician reviewed the recommended setup with the Area Sales Manager or Area Service Manager, and identified all necessary variations to satisfy the customer's particular application?

### **2-C: Unpacking:**

1. Check that all components and accessories are on hand, and agree with the customer's order.

2. Remove all components from their packing material, checking to make certain that all parts are accounted for and no parts are damaged. Advise the shipper immediately, if damage has occurred. Order any parts necessary to replace those which have been damaged. Keep the shipping container and packing material for future use. Check the packing list.

3. Collect all necessary installation manuals and prints, including Certified Prints, for the Scale being installed.

### **2-D: Safety:**

As is the case with any material handling equipment, certain safety precautions should be observed during operation:

1. Never load the platform beyond its rated capacity. Refer to the rating on the serial number plate if in doubt.

2. Ensure that any structure which supports the platform is capable of withstanding the weight of the platform plus its rated capacity load.

3. Do not load the platform if there is any evidence of damage to the platform or supporting structure.

4. Use safety chains or other suitable restraining devices if there is any possibility of the load shifting, falling, or rolling from its position on the load receiver.

5. Do not leave the platform unattended when it is loaded.

## **2-E: Recommended Installation Sequence:**

After pit is completed, follow this sequence:

Measure pit squareness, depth, width, and length against certified prints

Measure cast-in anchors, pier elevation on all piers against certified prints

Dimensions MUST be correct before installing scale hardware

Using packing list, be sure all scale elements/parts have arrived intact and Undamaged

Then install:

Base Plate Assemblies

Check Stands

Wood blocking and cribbing

Weighbridge Steel

Weighbridge Sections

Load Cell Flexure Assembly

Adjusting Elevation

Leveling Load Cell Flexure Assemblies

Grouting Load Cell Baseplates

Checkrods

Grouting Check Stands

Check Rod Adjustment

Deck coping, manholes, deck forming, deck rebar

Grounding

Rail and anti-creep devices

Form and pour concrete deck

When deck is cured, install:

Complete wiring of load cells

Instrumentation and any peripheral equipment

Calibration and testing

## **2-F: Foundation Inspection**

Excerpts from Fairbanks Scales form FF-2267; Foundation Field Check list

A Foundation Inspection should ALWAYS be performed prior to Scale installation, to confirm the Foundation is constructed correctly and is ready for installation. If possible, this should be done prior to the scale shipment.

### **TOOLS REQUIRED:**

Certified drawings and site plan.	2' to 4' level
25' & 100' steel tape measures	Hammer and concrete nails
Hacksaw	laser or builders level if possible
String line (construction string)	straight edge for pit foundations
Construction Spray Paint (upside down type, for marking concrete)	

Perform the following Foundation checks. It is recommended to keep a copy of the check list with the job file. ALWAYS familiarize yourself with the CERTIFIED FOUNDATION PRINTS for the job you are working on as model numbers and their specifications are subject to change.

- 1:** Site Plan and Certified Prints should be thoroughly reviewed to confirm accurate locations to the scale and all extra items ( scoreboards, lights, poles, etc.) that are included.
- 2:** Check for truck and crane access, overhead wires, fences, green concrete, etc. .
- 3:** Dimensional length and width check; check all 4 sides and record on chart.
- 4:** Diagonal measurements check to verify that the Foundation is square and record on chart. These measurements should be equal, or within ½ inch. Greater error could result in the scale not fitting in the Foundation.
- 5:** Check ALL pier heights to make sure they are at the correct elevation and record on chart.
- 6:** Check the pit walls to verify they are straight.
- 7:** Verify Ground Rod locations.
- 8:** Verify conduit locations and pull strings.
- 9:** Verify that drains and sump openings are piped correctly are clear of debris.
- 10:** Check the end coping to ensure they are centerline and that the coping is correct for the scale being installed (10', 11', 12', width, etc.). Check all coping, side and end, for hollow areas.
- 11:** Verify location(s) of any and all required embeds

Record all measurements and observations. Physically mark any discrepancies with the marking paint. Do not proceed with Installation until corrections have been made.

**2-G: Foundation Inspection Check list**

50538-3A

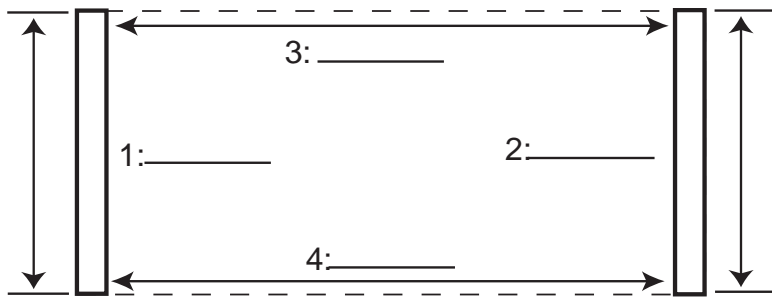

**Length & Width Check**

**Diagonal Measurements Check**

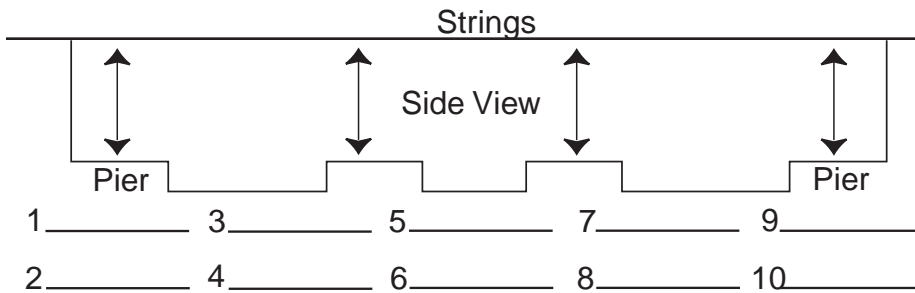
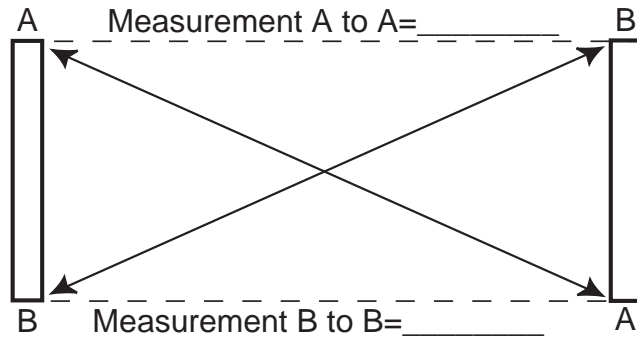

**Pier Height Check**

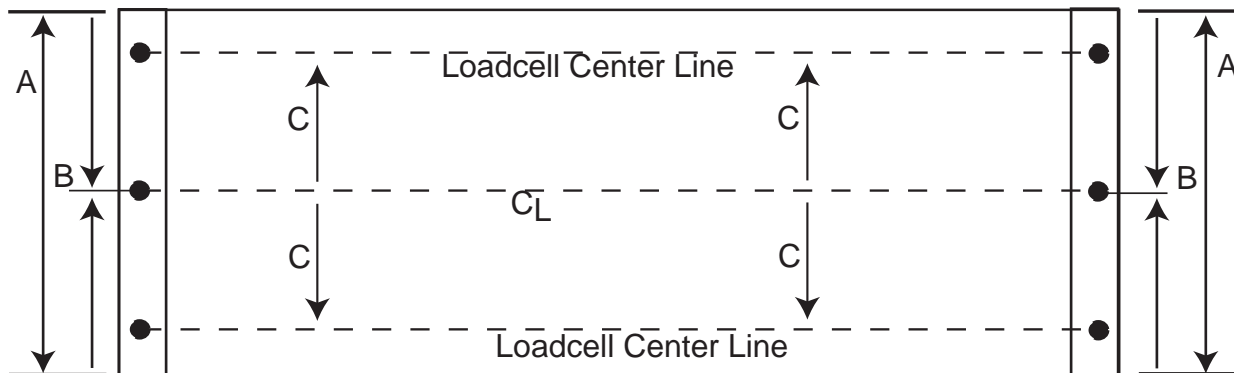

A = Coping length  
 B = 1/2 of the coping length, or Centerline  
 C = Distance from Centerline to load cell Center lines

● = Concrete Nails  
 C<sub>L</sub> = Centerline of Scale

## **2-H: Base plate assemblies:**

**Caution: Base plates weigh approximately 245 lb.each. Work Safely.**

**1:** Clean the top of the piers thoroughly, and ensure they are free of any oil or grease deposits. Clean the threads of all base plate pier bolts with a wire brush, using a thread file to restore any damaged threads. Lightly grease the threads, and ensure the threads are clean and in good condition by running a threaded nut down and up the full threads of the bolt. Remove all nuts from the pier bolts.

**2:** Place several short lengths of wooden 2 X 4's or 4 X 4's in the center of the pier bolts, and place the base plate onto the wooden blocking on the pier, guiding the 4 pier bolts into the 4 corner holes of the baseplate.

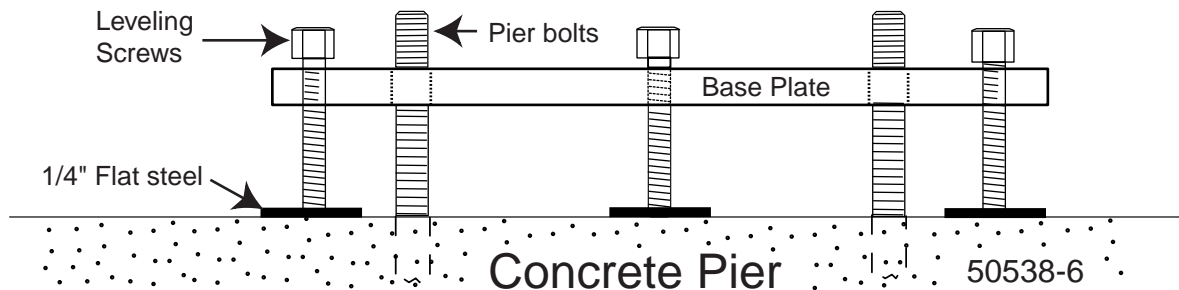

**3:** Insert greased leveling screws into the provided tapped holes in the base plates, and place a cut piece of 1/4" Flat Steel under each leveling screw. Adjust each screw to raise the base plate off of the blocking and to approximately level the base plate. Remove the blocking from underneath the base plate. Place flat washers and nuts on the pier bolts loosely.

## **2-I: Check Stands:**

**1:** Clean the top of the piers thoroughly, and ensure they are free of any oil or grease deposits. Clean the threads of all check stand pier bolts with a wire brush, using a thread file to restore any damaged threads. Lightly grease the threads, and ensure the threads are clean and in good condition by running a threaded nut down and up the full threads of the bolt. Remove all nuts from the pier bolts.

**2:** Place several short lengths of wooden 2 X 4's in the center of the pier bolts, and place the check stand onto the wooden blocking on the pier, guiding the pier bolts into the holes of the check stand.

**3:** Insert greased leveling screws into the provided tapped holes in the check stands, and place a cut piece of 1/4" Flat Steel under each leveling screw. Adjust each 5/8-11 X 4" screw to raise the base plate off of the blocking and to approximately level the check stand. Remove the blocking from underneath the check stand. Place flat washers and nuts on the pier bolts loosely.

## 2-J: Weighbridge Steel:

**Caution: Individual Steel beams can weigh as much as 5,500 lb. each. Work Safely.**

### **Assembling in Sections:**

It is recommended to assemble the weighbridge in 3 sections near the pit, with each section located near its intended installation location. The means to safely move and position the various steel beams will be required to facilitate the assembling of the weighbridge.

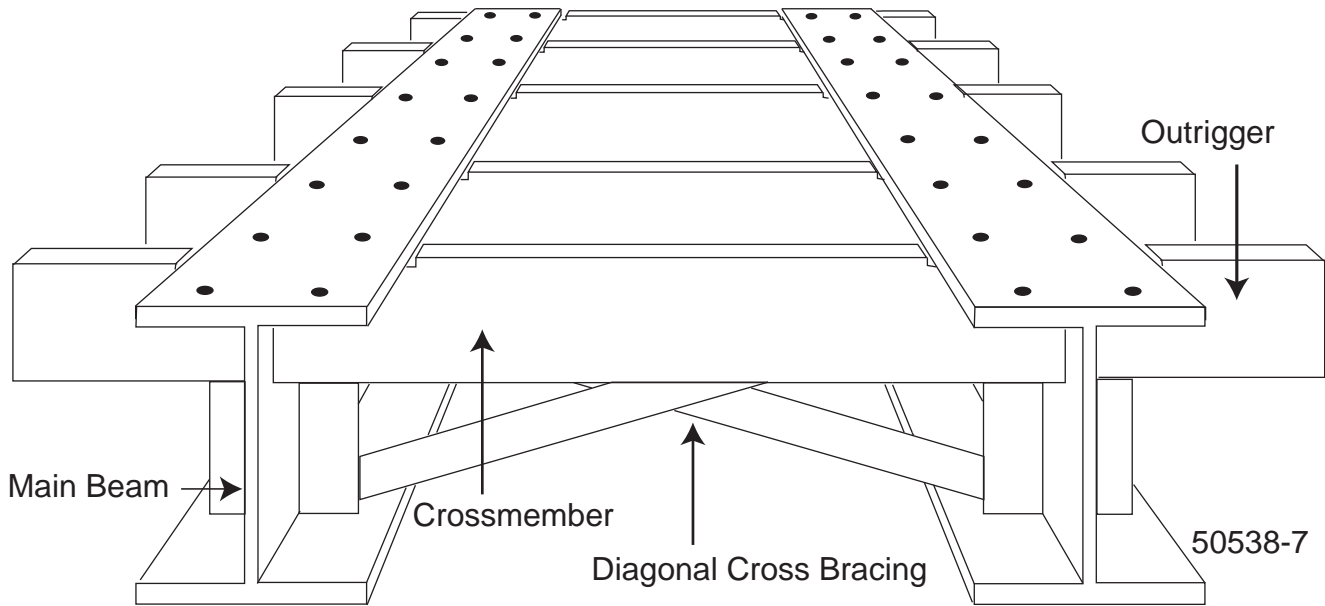

A suitable capacity hydraulic crane, and personnel familiar with safe and effective rigging methods using flexible non-metallic rigging of suitable capacity is recommended to handle and position the beams.

The Diagonal Cross Bracing is **not installed** until the Weighbridge is in the pit, and has been made plumb, is squared up and has been leveled.

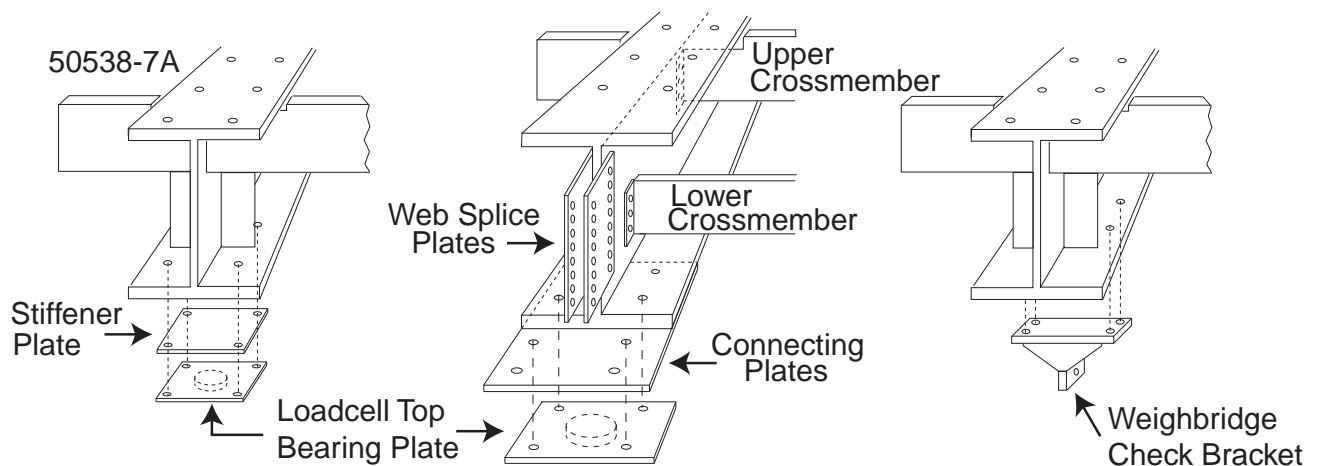

**2-K: Weighbridge Hardware**

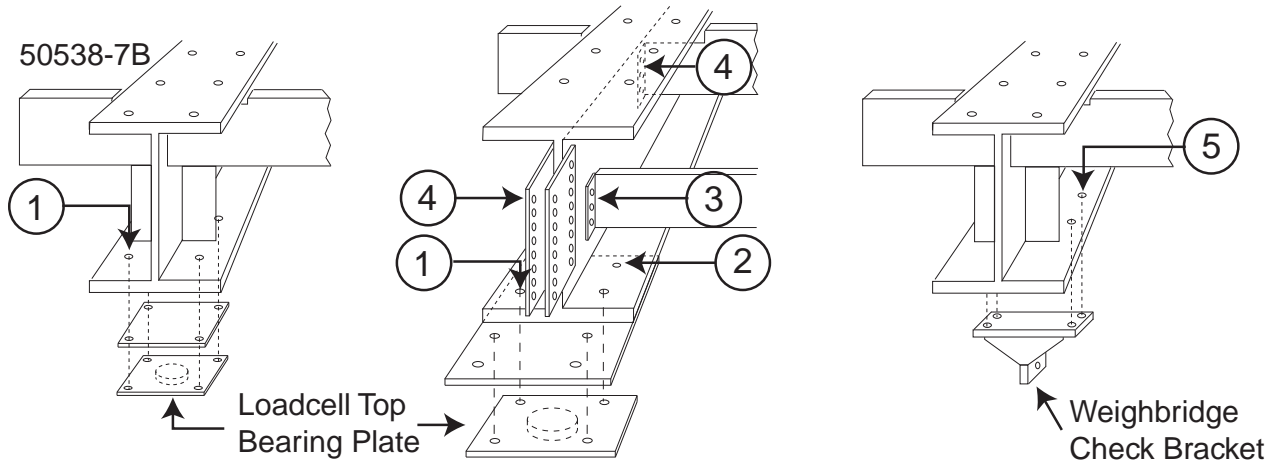

**1:** Part # 54532; 3/4-10 X 3" Hex Bolt. Qty 32 required to connect the load Cell Top Bearing Plate Assy's to Main Beam bottom flange. Their final Torque value is 150 foot pounds.

Note: The Load Cell Top Bearing Plate Assy mounting holes are tapped 3/4-10.

**2:** Part # 54229; 3/4-10 X 3 1/2" Hex Bolt A325 with Nut. Qty 16 required to connect the mid section connecting plates to the bottom of the Main Beams. These bolts are installed to the connecting plates end, outside holes only. Their final Torque value is 250 foot pounds.

**3:** Part # 54199; 3/4-10 X 2 1/4" Hex Bolt with Nut. Qty 36 required to connect the lower cross members to the Main Beams. Their final Torque value is 250 foot pounds.

**4:** Part # 54217; 3/4-10 X 3" Hex Bolt A325 with Nut. Total Qty 232 required. Their final Torque value is 250 foot pounds.

Qty 168 required to connect Crossmembers and Outriggers to the Main Beams.

Qty 64 required to connect the Web Splice Plates to the Main Beams at the Mid Sections.

**5:** Part # 54402; 1" X 3 1/2" Hex Bolt A325 with Nut. Qty 32 required to connect the Check Brackets to the bottom of the Main Beams. Their final Torque value is 640 foot pounds.

**Not Pictured:**

<b><u>Part #</u></b>	<b><u>Description</u></b>	<b><u>Qty</u></b>	<b><u>Used On:</u></b>
54342	1 1/2-6 Hex Nut	32	Check Rods
54897	1 1/2-6 Jam Nut	32	Check Rods
58617	1 1/2 Spherical Washer Set	32	Check Rods
55766	3/4" X 1 1/4" Bar, J Box	5	Junction Boxes

## 2-L: Assembling Weighbridge Sections

**1:** Identify each main beam pair per the certified prints, and select the appropriate end section beams as the first to begin assembling. Place one main beam onto blocking, ensuring it is supported and stable. Place the second main beam onto blocking, in parallel with the first main beam, and close enough together to enable the middle crossmembers to be placed into position

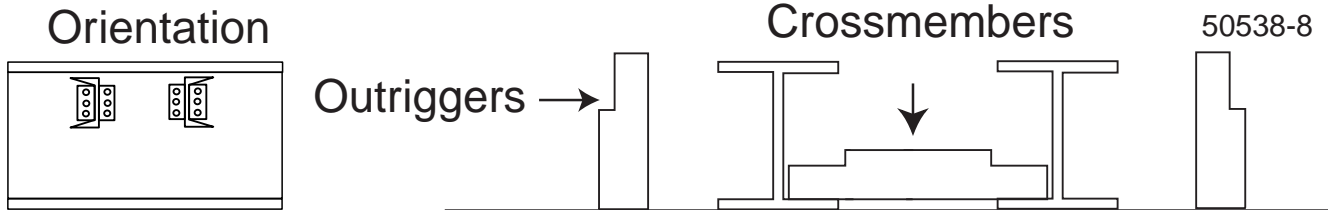

temporarily by laying them down onto the bottom flanges of the main beams and in-between them. Note the correct orientation of these crossmembers as indicated by the certified prints. Place the outriggers near their intended installation location, and the mounting hardware.

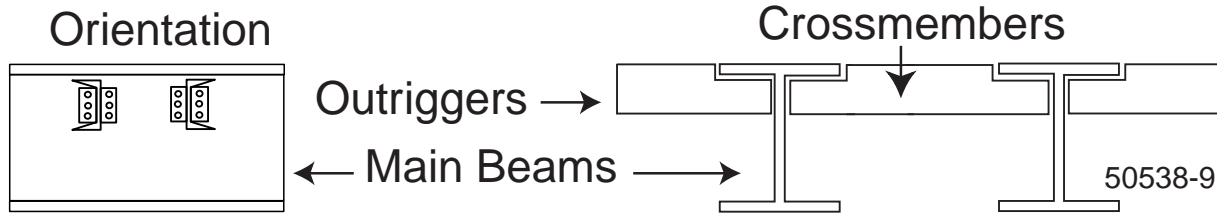

**2:** Starting at one end of the section, install the first crossmember into position, along with both outriggers, leaving the bolts loose. Install the next crossmember, with its outriggers, and proceed in order to the other end of the section. A chain come-along (with suitable capacity) at the opposite end of the main beams can be used to slowly draw the main I-beams together as the crossmembers and outriggers are being installed. When all crossmembers and outriggers have been installed in this manner, tighten all bolts. Do not tighten to their final torque value at this time.

**3:** Locate the Weighbridge Checking Bracket locations on the lower flanges of the main beams, and per the Certified Prints. Raise that area higher and support it with blocking, the bracket will require a minimum of fifteen (15) inches of clearance. Install and tighten the weighbridge checking bracket.

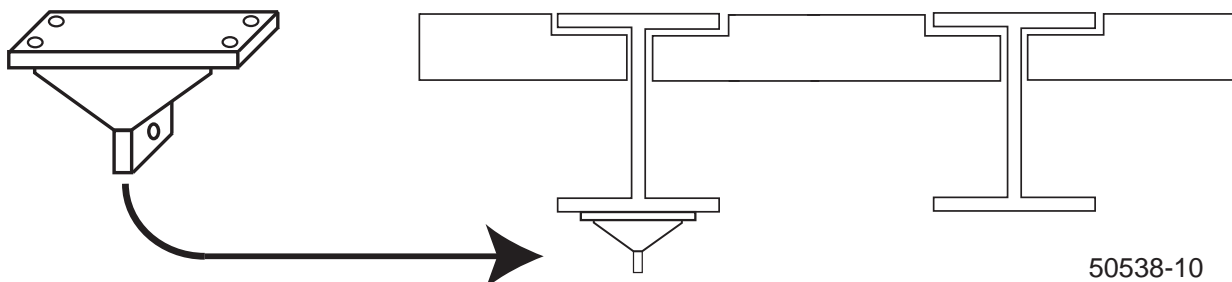

**4:** Install the stiffener plate and the top bearing plate assemblies. The mounting bolts will install into the Top Bearing Plates threaded holes. Do not tighten to their final torque value at this time. Do not perform any welding to the end sections at this time.

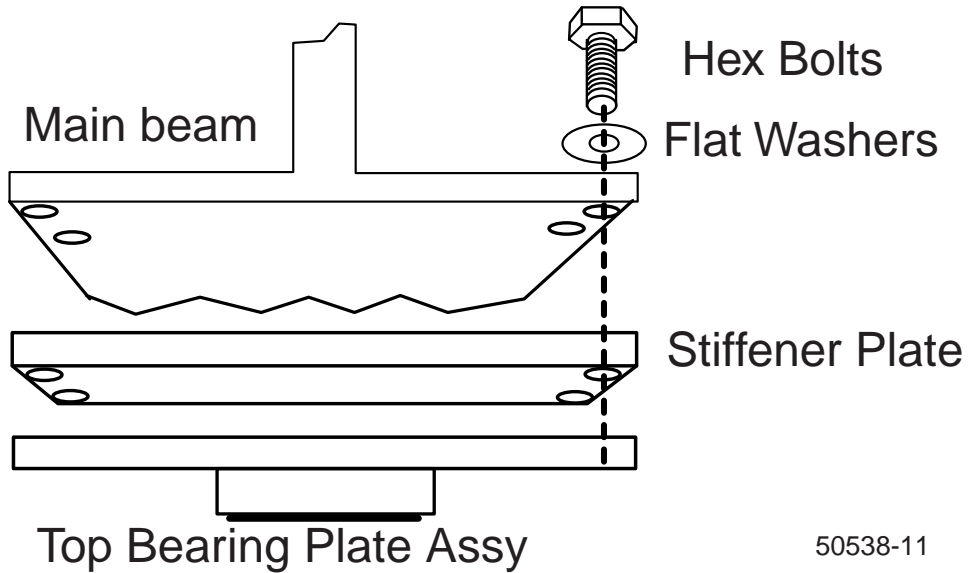

50538-11

**5:** In similar manner, assemble the center section (s), and the other end section.

## 2-M: Installing Weighbridge Sections

**Caution: Weighbridge Sections can weigh as much as 17,000 lb. each. Work Safely.**

**1:** Place wooden blocking and cribbing material suitable for supporting and jacking the weighbridge steel into position near each pier and base plate. Each section will require four points of support, therefore arrange the placement of these supports accordingly. It is recommended to set blocking to support the weighbridge against the pit wall, and 1 to 2 inches higher (than the certified prints indicate its final elevation should be) at this time. If Safety Piers have been installed, they can be utilized in lieu of blocks provided they are thoroughly and completely cured.

**2:** With a crane and rigging (4 leg drop) of suitable capacity, install an end section into the pit, and onto the supports. Set up a mason line to check and ensure that the centers of the main beams are centered on the rail cutouts in the concrete approaches for the entire section.

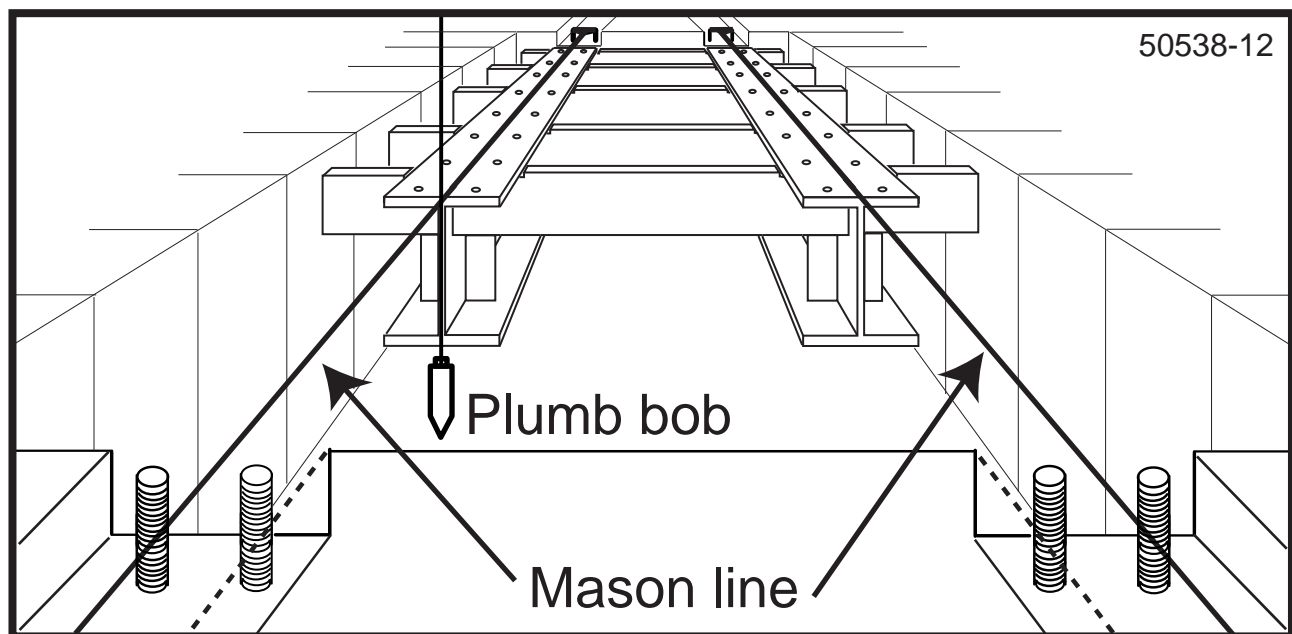

**3:** Ensure the distance from the approach pit wall is correct to ensure equal clearance at both ends.

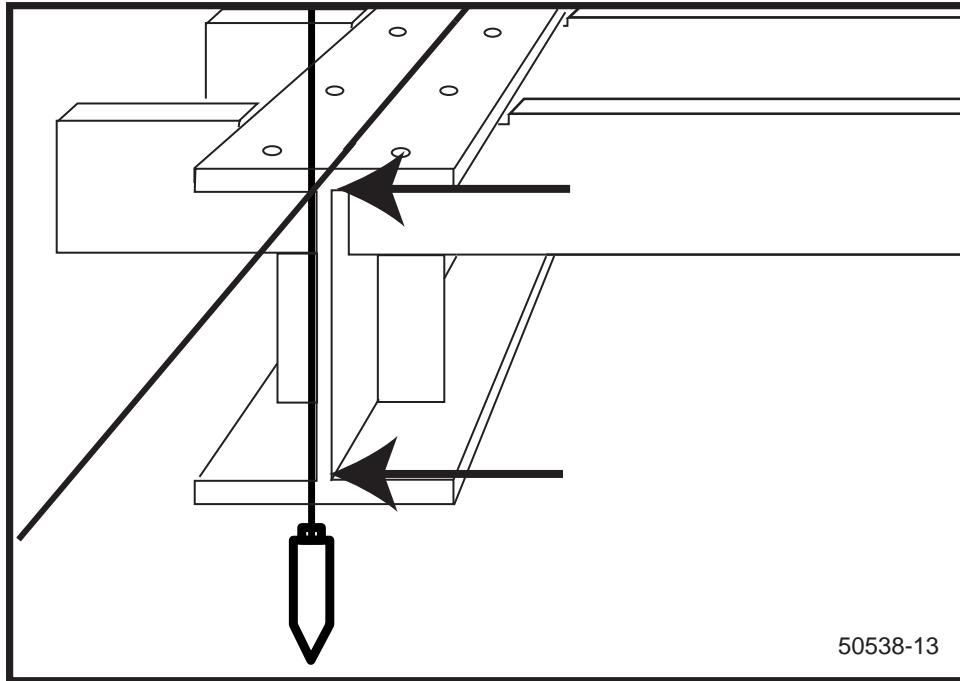

ABOVE: Check weighbridge steel for squareness by suspending a plumb bob at the juncture of the previously established "centering" line, and at the juncture of the middle web of the main beams. Measure and observe the distance between the plumb bob line and the web, it should be the same at the top and bottom.

**4:** When end section has been centered, install the middle section, and connect the sections together as indicated on the certified drawings. The top flange of the joined main beams must be level and on the same plane to fully support the track rail without shimming. When this is completed, and all plates and bolts have been installed, tighten all bolts to their final torque value.

**5:** Install the other end section in the same manner, checking to ensure that the centers of the main beams are centered on the rail cutouts in the concrete approaches for the entire scale.

Ensure the top flanges of the main beams are level, install all plates and bolts, and tighten all bolts to their final torque value.

**NOTE:** Do not weld in the Cross Bracing until the bridge is leveled and the dead load is balanced. See **Step 9 on page 35**.

**2-N: Load Cell Flexure Assembly:**

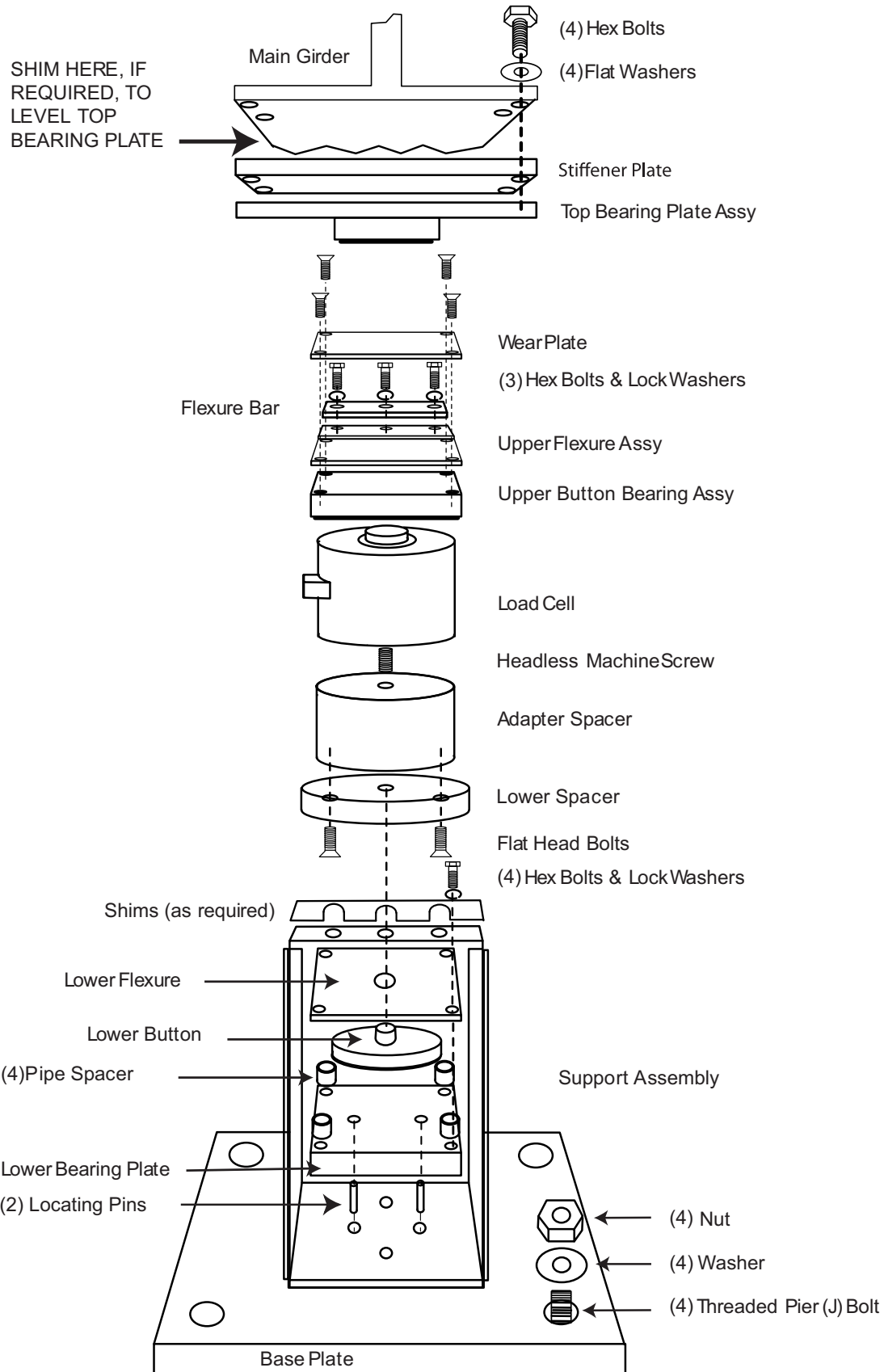

50538-14A

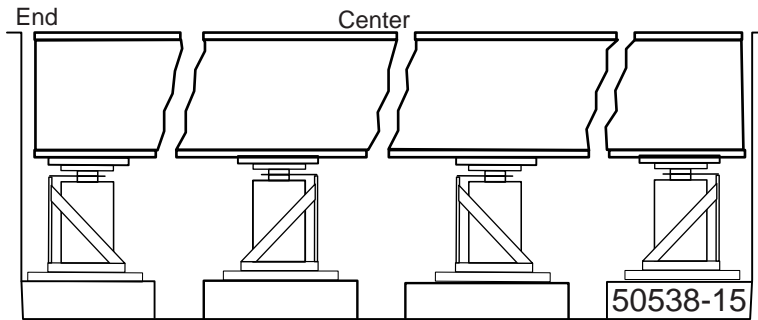

Referring to the detail above, note that the "open" side of the assemblies at end sections face the center of the scale; middle sections have assemblies installed with the "open" side facing the end of the scale.

**TIP:** For Analog Instrumentation, measure the bridge resistance of each load cell, and pair the closest matches for installation in each section.

### **Lower Assembly:**

- 1:** Ensure the base plate is clean and free from any dirt and debris. Place the support assembly into position, correctly orienting it in the appropriate direction and approximately centered on the base plate.
- 2:** Apply grease and install the two 5/8-18 x 1 1/4" socket-set screws (headless) in the holes at the bottom plate of the support assembly to serve as locating pins for the lower bearing plate.
- 3:** Place the lower bearing plate in position with the two holes engaging the locating pins.
- 4:** Attach the Lower Spacer to the Adapter Spacer using two (2) 5/8" X 1 1/4"
- 5:** With the load cell supported on its side, apply grease and install the Adapter Spacer to the base of the load cell using the 3/4-16 x 1 1/4" socket-set screw (headless).
- 6:** Place the lower button's threaded stud through the center hole of the bottom flexure. Apply grease to the threads.
- 7:** With the load cell supported on its side, place the lower button/flexure against the load cell lower spacer with the center hole aligned. Then screw the lower button/flexure into the load cell lower spacer until all threads are very snug. Turn the lower button with large pliers being careful not to bend or damage the lower flexure in any way.
- 8:** Position the four spacers at the corners of the lower bearing plate concentric with the tapped 1/2" holes.
- 9:** Carefully lift the load cell assembly upright, and place it into the support assembly with the load cell wiring junction facing the open side of the support assembly.
- 10:** Apply grease and install four 1/2"-13 x 1 1/2" screws and lock washers through the lower flexure and pipe spacers, and turn them into the corner holes of the lower bearing plate.

## Upper Assembly:

1: Place the upper button bearing assembly to the underside of the upper flexure assembly. With the wear plate correctly orientated as to its corner countersunk holes, apply grease and install the four ¼-20 x ½” flat-head screws through the wear plate, flexure assembly, and into the bearing assembly.

2: Position the flexure and bearing assembly on the top of the load cell with the three holes at the edge of the flexure facing the three holes in the mounting block at the upper rear of the support assembly.

3: Position the mounting block bar, and loosely install three ½-13 x 1-1/4” hex bolts and lock washers to hold the flexure assembly and bar into position. Apply grease to the bolt threads.

## 2-O: Adjusting Elevation:

1: With all load cell support assemblies installed, assembled, and placed upon the load cell base plates as described in the preceding pages, prepare to carefully lower the weighbridge onto each load cell support assembly one at a time with a hydraulic jack of sufficient capacity.

Starting with an end section, lower the weighbridge onto the load cell support assemblies at that section one at a time.

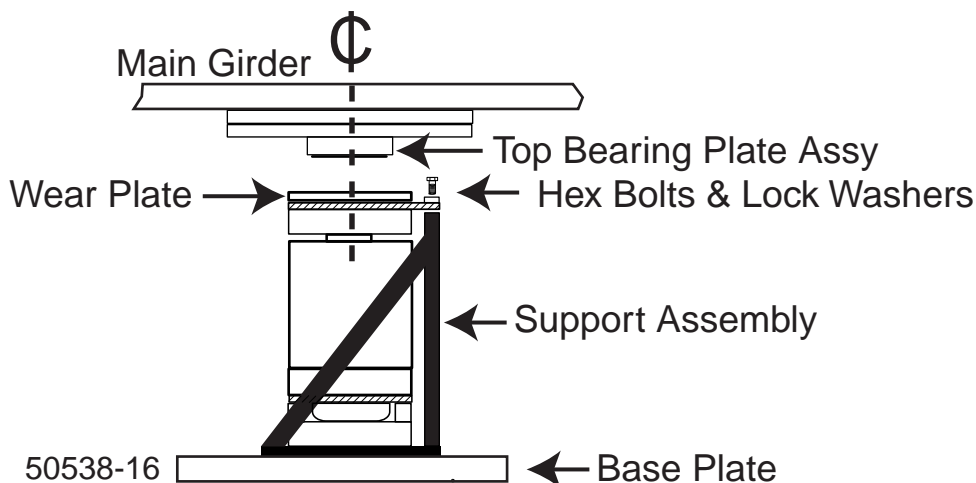

**Ensure that the top bearing plate centers on the wear plate at each flexure**, moving the entire assembled load cell support assembly on the base plate as required to accomplish this centering. Ensure the hex bolts that connect the top flexure plate to the support assembly stand are inserted but not completely tightened before lowering the weighbridge onto the load cell support assembly. Continue until the weighbridge is completely supported by the load-cells.

**DO NOT REMOVE THE SUPPORTING BLOCKING AND CRIBBING AT THIS TIME.**

**LEAVE THEM IN PLACE CLOSE TO THE MAIN BEAMS TO SERVE AS A SAFETY PIER.**

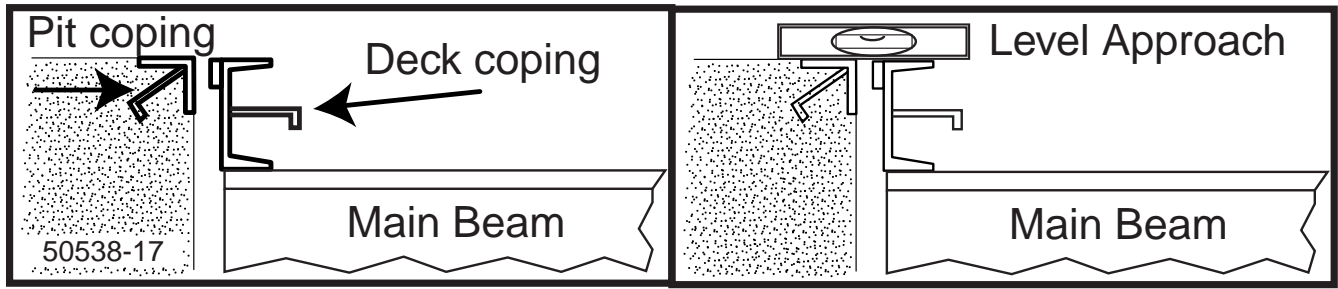

**2:** For the end sections, the elevation reference is the end wall (approach) pit coping. Place and clamp deck coping across the main beams at an end section facing the pit wall coping. Adjust the load cell base plate leveling screws of both base plates in the end section to level the approach as shown above. Ensure both base plates are also level to within 1/64" per foot.

**3:** Proceed to the next section, which is a middle section. Ensure the hex bolts that connect the top flexure plate to the support assembly stand are inserted but not completely tightened. Ensure that the top bearing plate centers on the wear plate at each flexure, moving the entire load cell support assembly on the base plate as required to accomplish this centering. Lower the weighbridge onto the load cell support assemblies.

**4:** For the middle sections, the elevation reference is both the absolute level of the main beams with respect to the end sections, and the equal loading of the loadcells that support the middle of the scale. Adjust the load cell base plate leveling screws to level the main beams. Alternately, a transit can be used to compare and maintain elevation, and a tightly stretched mason line. Ensure both base plates are also level to within 1/64" per foot.

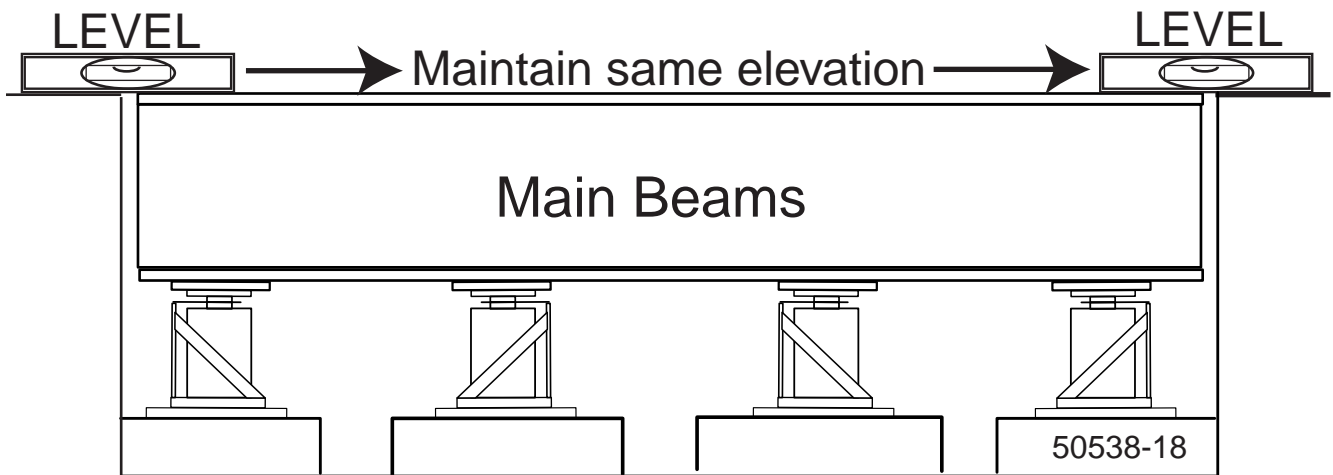

**5:** Repeat these steps for the remaining sections of the scale.

## 2-P: Leveling Load Cell Flexure Assemblies:

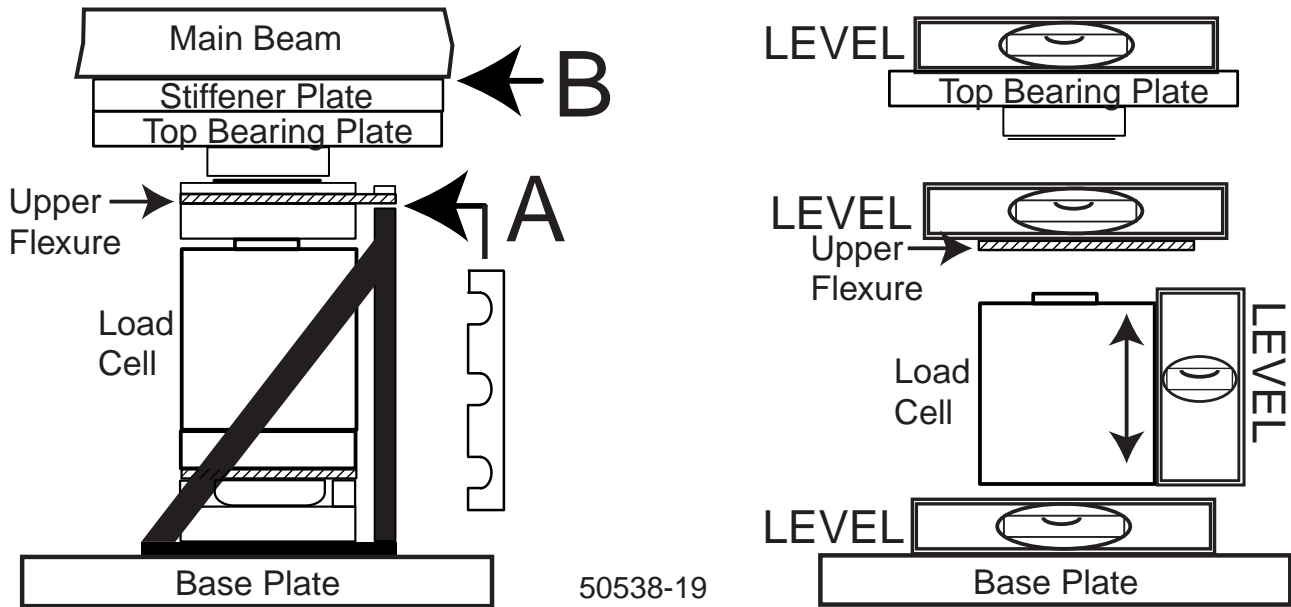

**1:** Starting at one end section, lift the main beam slightly from one load cell at a time and loosen the three screws that secure the flexure to the support assembly block, and note any space between the flexure and the block. Use a precision level across the flexure and add or remove shims between the flexure and the block to get best possible level on the flexure and insure there are no spaces or gaps (see "A" above). Tighten the three screws to torque specifications.

**2:** Check that the top bearing plate assembly is level and at right angles to the main beam web. If adjustment is necessary, install shims only between the main beam's lower flange and the stiffener plate ( see "B" above). Shims must extend the full length of the bearing surface.

**3:** Check that the load cell is vertical and that the top bearing plate is centered on the flexure wear plate. Adjust if necessary. Ensure the base plates, load cell, upper flexure plate, and top bearing plate assembly are level to within 1/64" per foot.

**4:** Continue for each load cell flexure assembly.

**5:** Providing a suitable power supply to connect to the loadcells, measure and record the mV/V output from each load cell in the scale. The resulting readings will indicate the current weight distribution of the scale's deadload among the eight (8) points of support. The outputs will be greater for number's 3, 4, 5, and 6 because there is physically more deadload weight upon them.

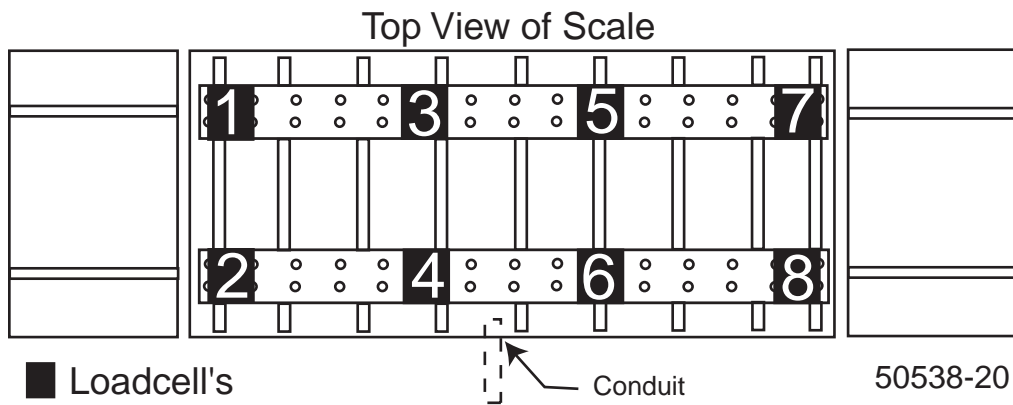

This final base plate elevation adjustment should be made to match the mV/V outputs of the load cells to assure correct distribution of the scale's deadload among the eight (8) points of support. Adjust the base plate leveling screws (equally) to match loadcells 3, 4, 5, and 6. Then adjust to match loadcells 1, 2, 7, and 8. When this has been completed, ensure each load cell base plate is level to within 1/64" per foot.

NOTE: The load cell numbering sequence shown is designed for interfacing Fairbanks INTA-LOGIX technology instrumentation.

**6: Perform a final check to all:**

- Load cell base plates are level to within 1/64" per foot.
- All Cell assemblies are centered on base plates, & All Load cells are vertical and plumb
- Top bearing plate centers on the wear plate at each flexure
- Top bearing plate assembly and stiffener plates are level to 1/64" per foot and at right angles to the main beam web(s).
- Upper flexures are level to 1/64" per foot with weight and without weight, and shimmed properly
- Top flanges of the main beams are absolutely level and on the same plane as the end sections.
- There is correct distribution of the scale's deadload among the eight (8) points of support.
- All assembly hardware is secure

**7:** Insulate and separate each load cell's wiring from adjoining wires and from the steel with insulated electrical tape. Be certain load cell cables are isolated from contact with steel and not attached to any junction boxes.

**Be certain load cell cables are isolated from contact with steel and not attached to junction boxes. Welding ground should be kept as close to the electrode (welding rod) end as is practical.**

**DO NOT PERMIT ELECTRIC ARC CURRENT TO CONDUCT THROUGH A LOAD CELL(S)**

**8:** Weld the support stands to the load cell base plates per certified drawings. Welding ground must be on the same physical side of each load cell as the electrode (welding rod) end.

**9:** Install and weld all section "X" bracing per the certified prints.

**10:** All structural steel shall have one shop prime coat. Areas around field welded connections shall be painted. Immediately following the connecting of the members, the heads, nuts, and washers of all permanent bolts, all field welds after removal of residual flux, all abrasions of the shop prime coat, and all field erection marks shall be thoroughly covered with one coat of primer.

## **2-Q: Grouting Load Cell Baseplates:**

Grout becomes the base which supports the entire structure. Grout MUST be fully supporting the stands and plates with NO gaps or spaces. A good method is to build the forms slightly bigger than the stand to permit the pouring and the rising of the grout mixture.

The pier should be thoroughly saturated with clean water for a minimum of 4 hours. This will both prevent the dry pier concrete from absorbing water from the mix as it is poured, and greatly enhance the ability for the grout mix to bond with the pier.

### **1. Grout selection:**

Grout shall be precision, packaged dry, non-metallic, hydraulic, non-shrink, and non-gaseous.

Grout shall meet or exceed ASTM C-1107 and Corps of Engineers CRD-C621.

Grout shall be bleed free and attain a minimum of 8000 psi compressive strength in 28 days at flowable consistency.

Grout MUST be mixed to a flowable consistency as specified by the grout manufacturer.

Do not permit any loads upon the scale until the grout has reached the compressive strength of 8000 psi per the grout manufacturers instruction.

### **2. Surface preparation:**

- Surfaces to be grouted shall be prepared in accordance with the manufacturers instructions.
- Surfaces to be grouted shall be free of loose debris, grease, oil and other contaminant's.
- Contaminant's shall be removed using caustic soda or other approved concrete cleaners.
- All surfaces shall be flushed with clean water.
- Prior to pouring, all surfaces should be saturated with clean water for a minimum of 4 hours.

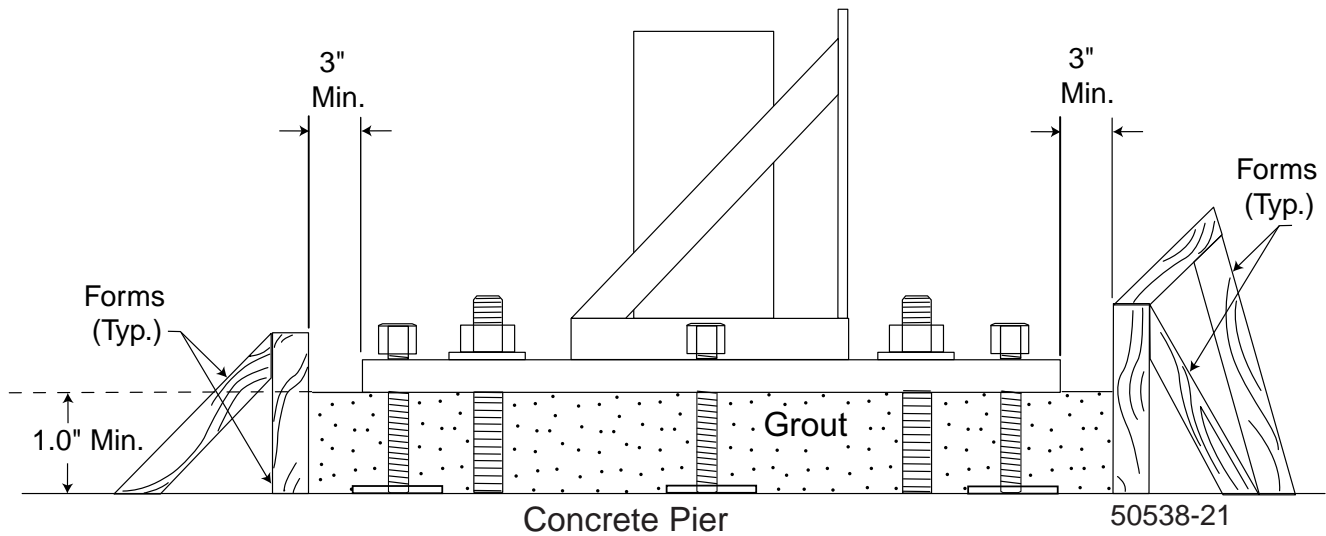

### **3. Forming:**

- Forming must be completed and installed before starting to pour grout.
- Forms shall be slightly larger (six to seven inches) than the dimension of the load cell base plate or checking stand.
- Forms shall be of sufficient strength, anchored properly, and sealed. Seal with caulk and use a form release agent on forms if required. Leave access for pouring grout in a convenient place.

### **4. Mixing and Pouring:**

- Mix grout per the manufacturers instructions until a very smooth, pourable mix is obtained. Be sure you mix enough quantity for the form you are filling.
- If necessary, use a large funnel or cone to direct mix into form and under stands.
- Pour the grout mix from one end until it fully reaches the other side and rises to fill the form completely. By using this method, there will be no gaps or air pockets. Vibrators are not recommended due to the danger of disturbing the placement of the load cell base plate(s). Ensure the grout mixture totally fills all voids.

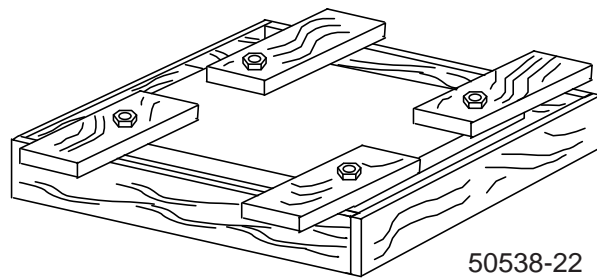
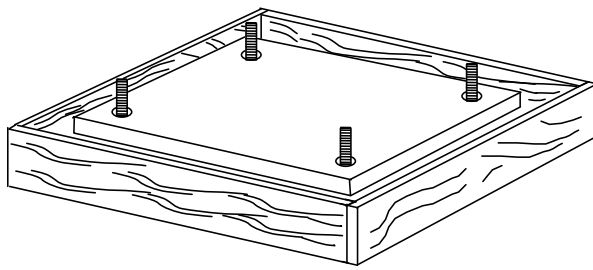

50538-22

TIP: Forms can sometimes be easily made and secured to the pier as shown above. Be careful not to tighten the pier nuts too tightly on the wooden forms. **DO NOT DISTURB THE LOAD CELL BASE PLATE'S LEVEL, ELEVATION, OR LOCATION IN ANYWAY !!!**

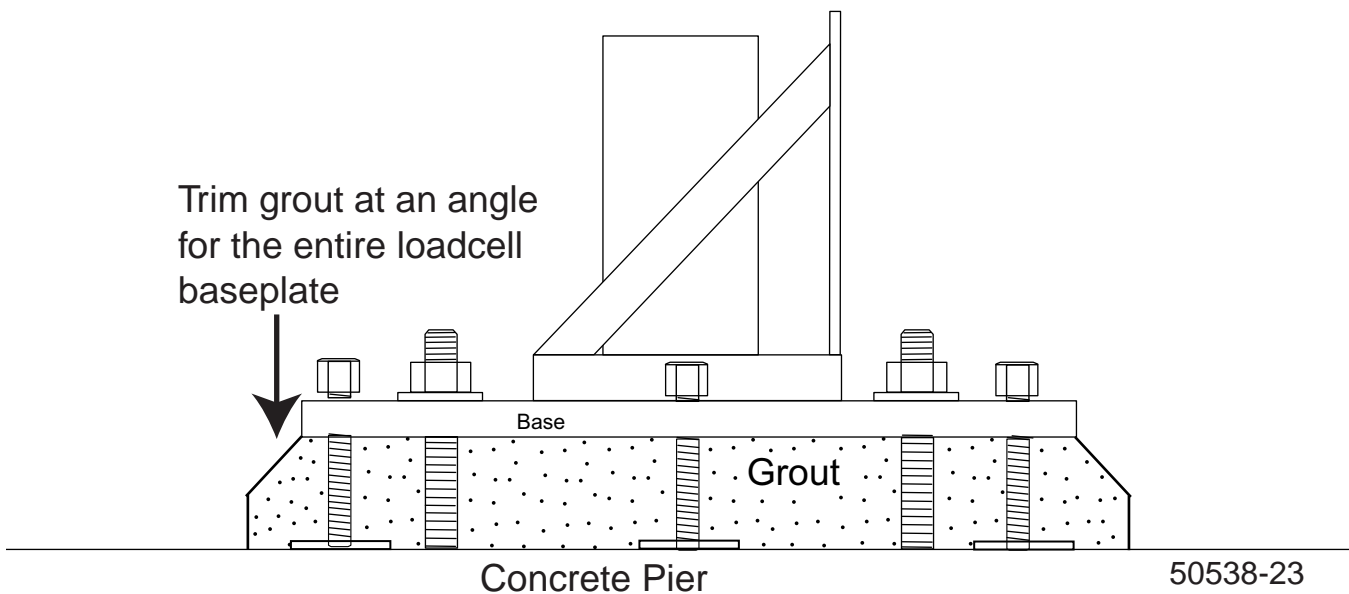

50538-23

- The A.A.R. requires that if grout extends beyond the base plate, it must be sloped away from the base plates and stands so that water will not pool and saturate the metal, thereby rusting it. The form may be larger than the base or stand by about 3" on all sides.

\*When grout is firm but can still be shaped, remove the forms and angle all four sides of the grout and away from the base plate or stand.

- The grout should be cured according to the manufacturer's recommendations on the package. For any unusual conditions, call the manufacturer for guidance.

- When the grout is fully cured, remove base plate leveling screws completely and discard, then fill the empty holes with silicon caulking. Tighten all load cell base plate pier bolt nuts.

## 2-R: Check Rods:

1: Check rods allow for vertical movement in order to transfer weight force to the load cells but they do not allow for lateral or side movement. Prepare the check rods, special convex / concave washer sets, and hardware for installation. Clean the threads with a wire brush, using a thread file to restore any damaged threads. Lightly grease the threads, and ensure the threads are clean and in good condition by running a threaded nut up and down the full threads of the checkrods.

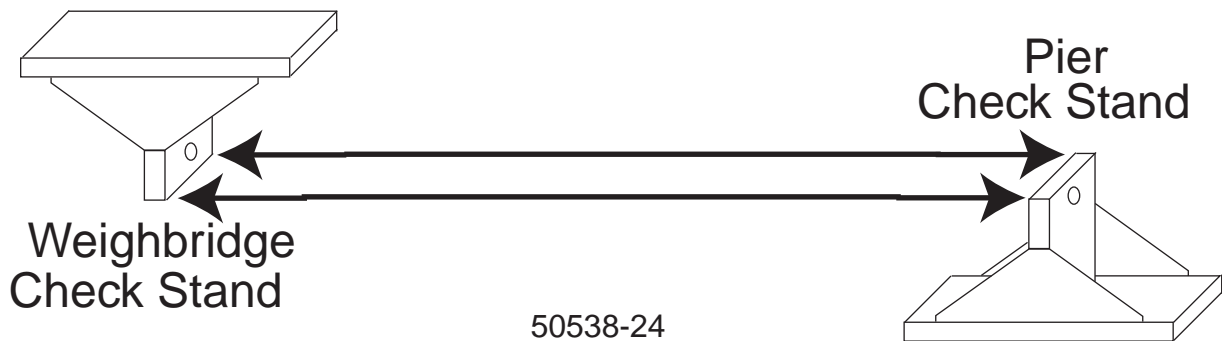

Ensure the check stands are parallel, and squarely face each other by measuring as shown above.

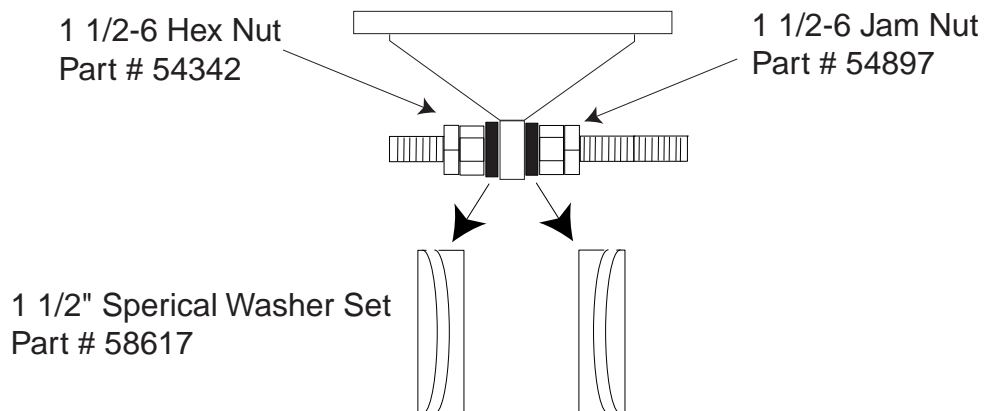

50538-25

Install two nuts and one washer set to each end of the check rod. Lightly grease the special washer set. Arrange and install the Special Convex - Concave washers as shown.

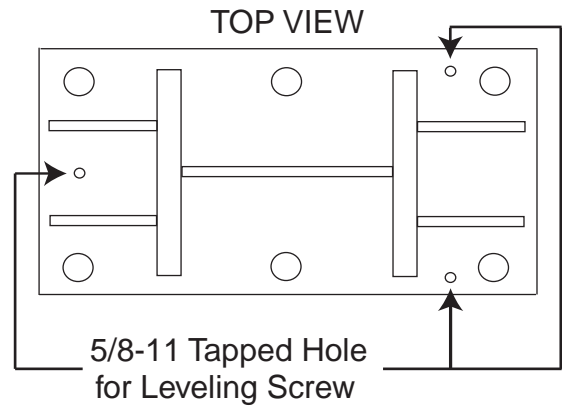
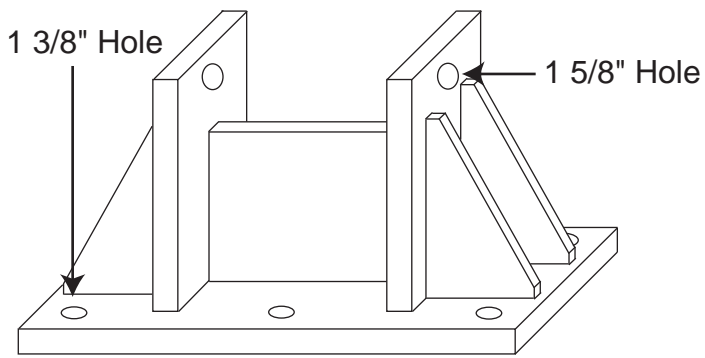

50538-26

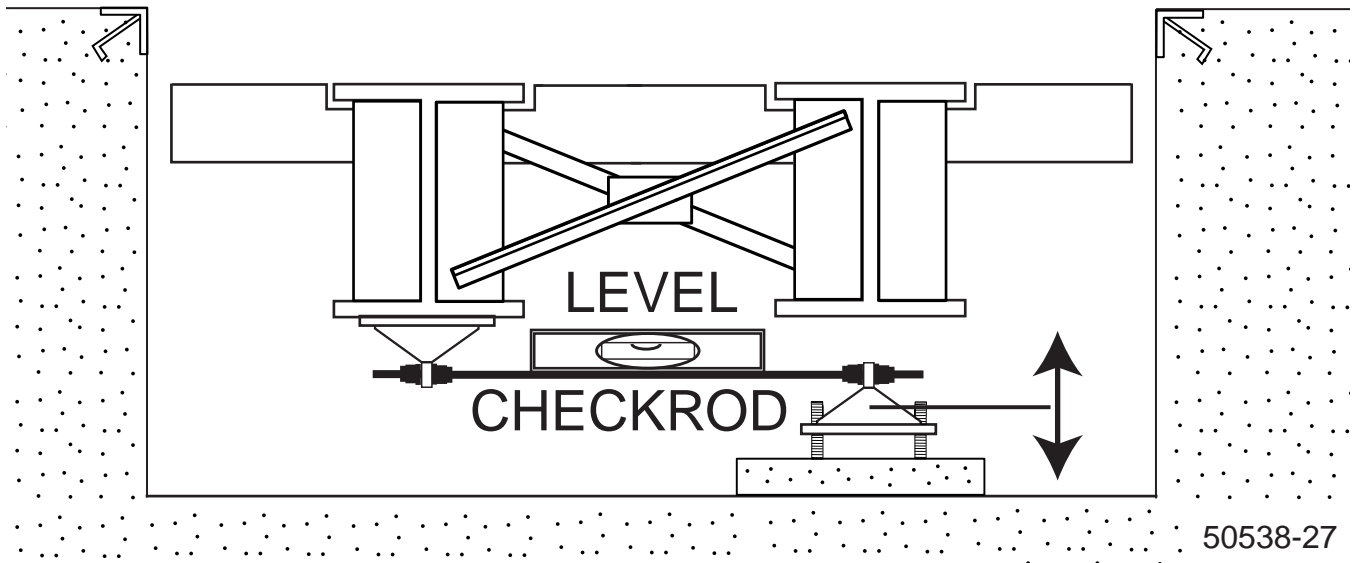
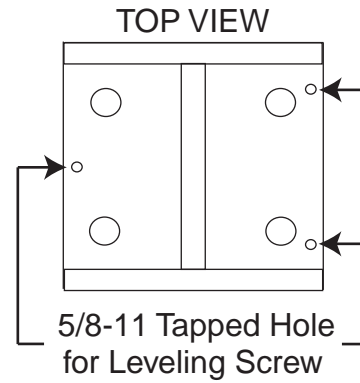
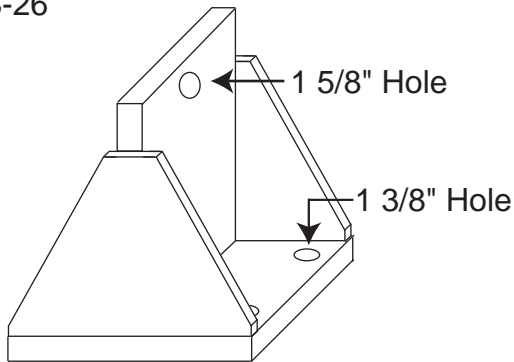

**2:** Install the check rod into position, and place the rest of the hardware onto both ends, leaving the hardware loose.

All check rods must be level within 1/100" per foot when weighbridge is at correct elevation. Raise or lower the Pier Checking stand with its leveling screws until this is achieved.

**2-S: Check Rod Adjustment:**

**NOTE:** See **Section 2-Q** for complete assembly descriptions of Grouting Check Stands, Grout Selection, Surface Preparation, Forming, and Mixing and Pouring.

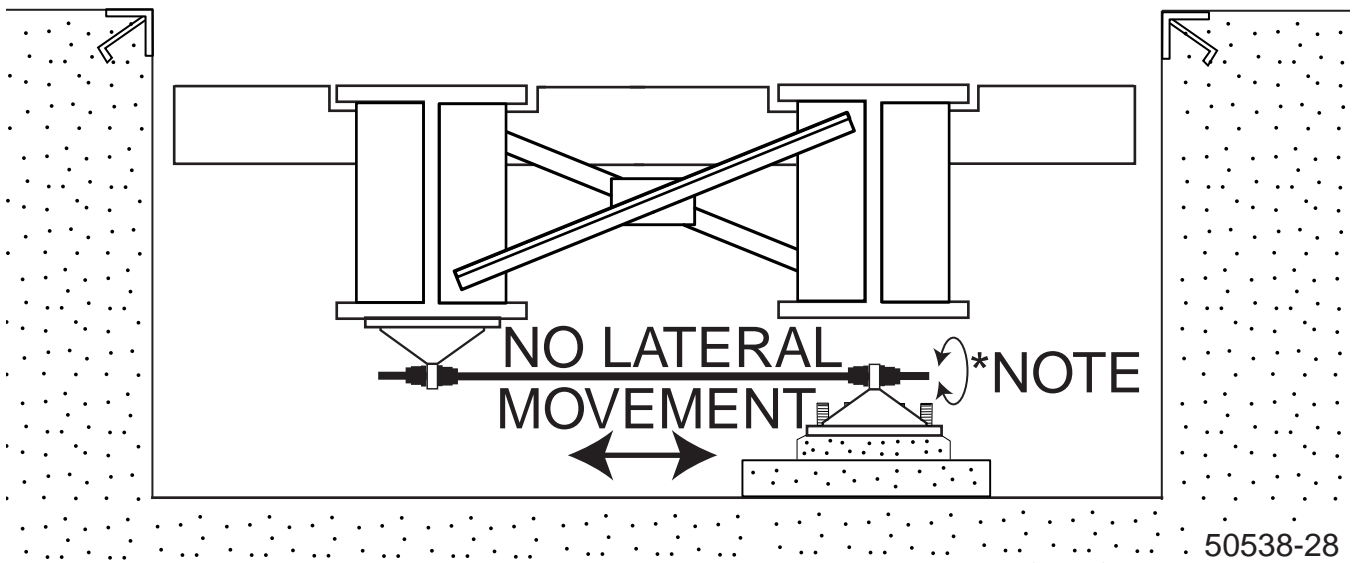

All checkrod threads and Spherical washer sets shall be greased.

\* **NOTE:** All checkrods shall be adjusted so there is no lateral movement at all, while the checkrod can be rotated to ensure the scale is not being subjected to any side forces or influence from them. Lock the double nuts together tightly.

**2-T: Deck Forming:**

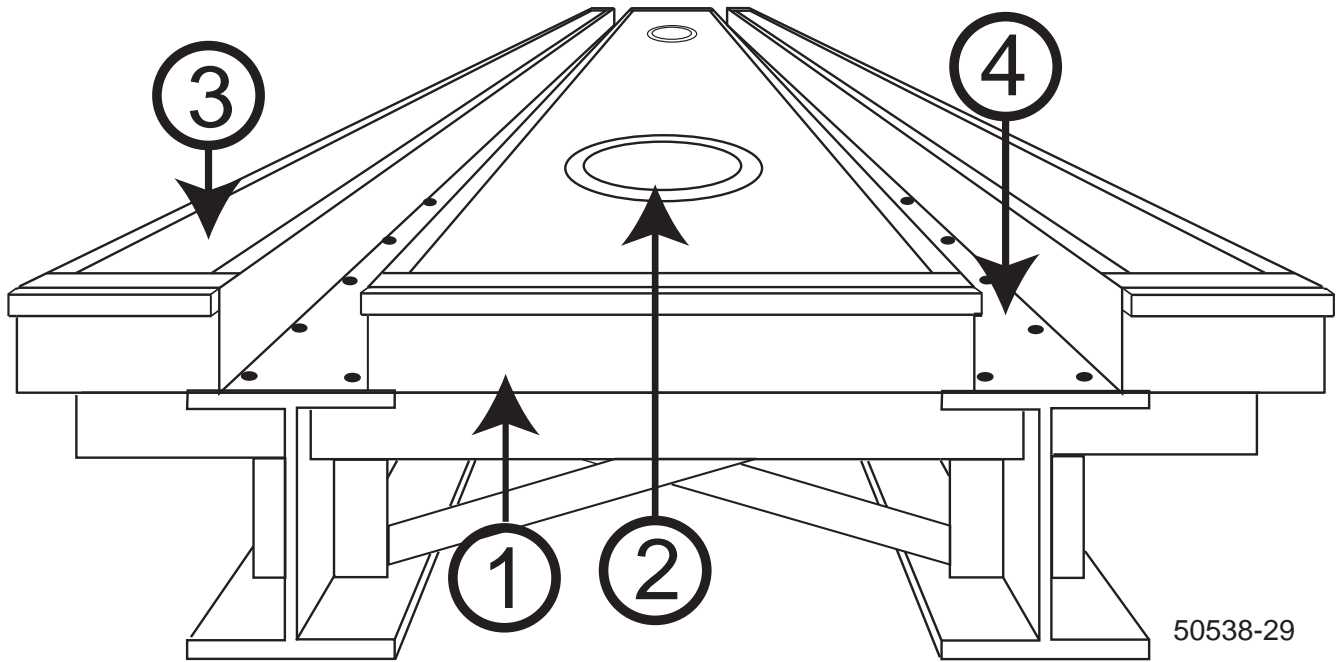

Above: 1: Deck Coping 2: Manhole access 3: Poured concrete 4: Rail pocket

Deck forming will prepare a custom fitted deck that provides correct clearance while conforming to the pit walls and rails. The construction of the deck provides several custom "pans" to contain the reinforcement rods, manholes, and to support the poured redi-mix concrete until it cures.

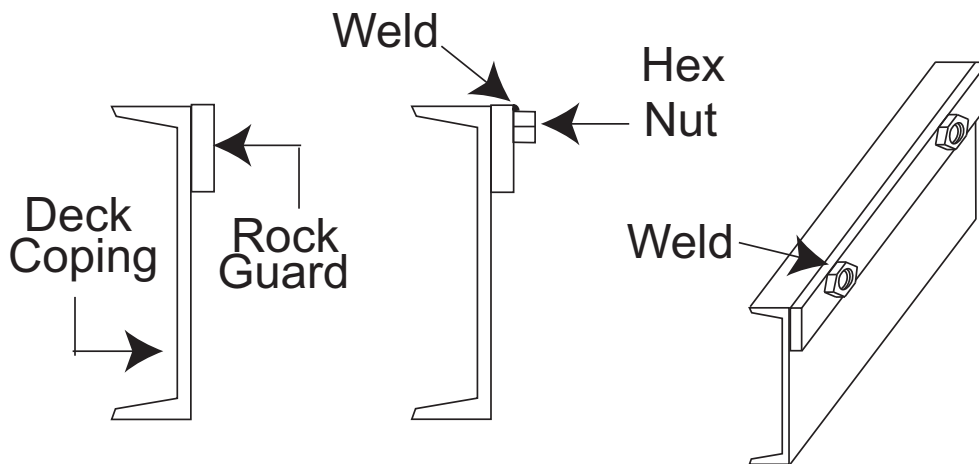

50538-30 Rev. 2

**1:** To maintain a 5/8" spacing between the scale deck and the pit wall, machine screw nuts are welded to the outer face of the channel iron below the rock guard at each end, and at sixteen 16 inch intervals, more if required. Use 5/8 inch nuts, which measure 1.0 inch across the flats.

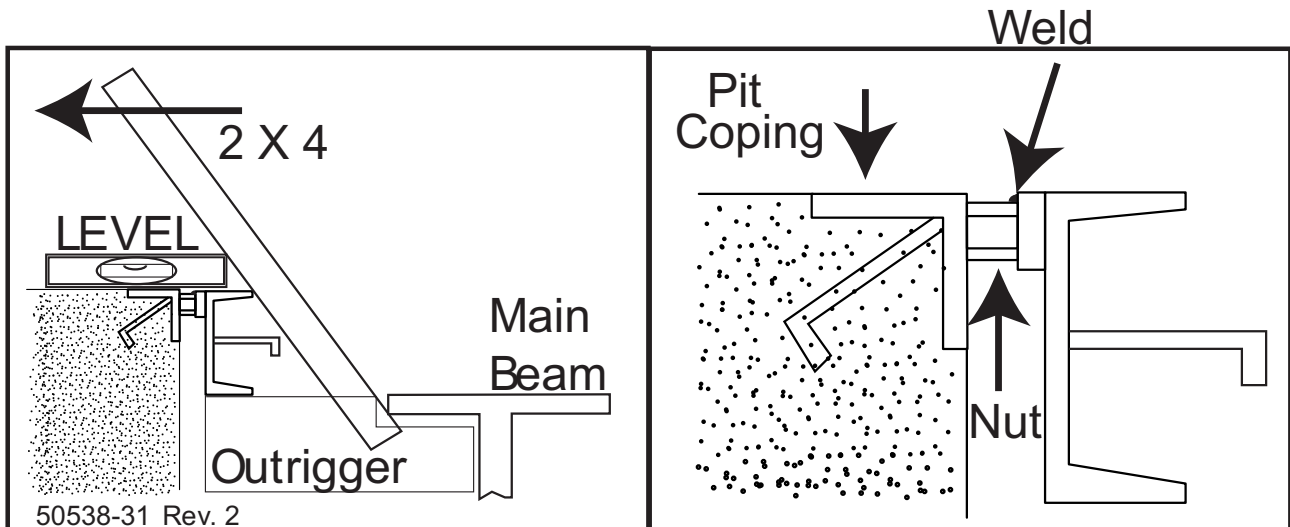

**2:** The deck channel is then placed into position. A 2 X 4 can be used as shown to help force and position the deck channel against the pit wall. Ensure the deck channel is level with the pit coping, then weld the nut to the pit coping as shown.

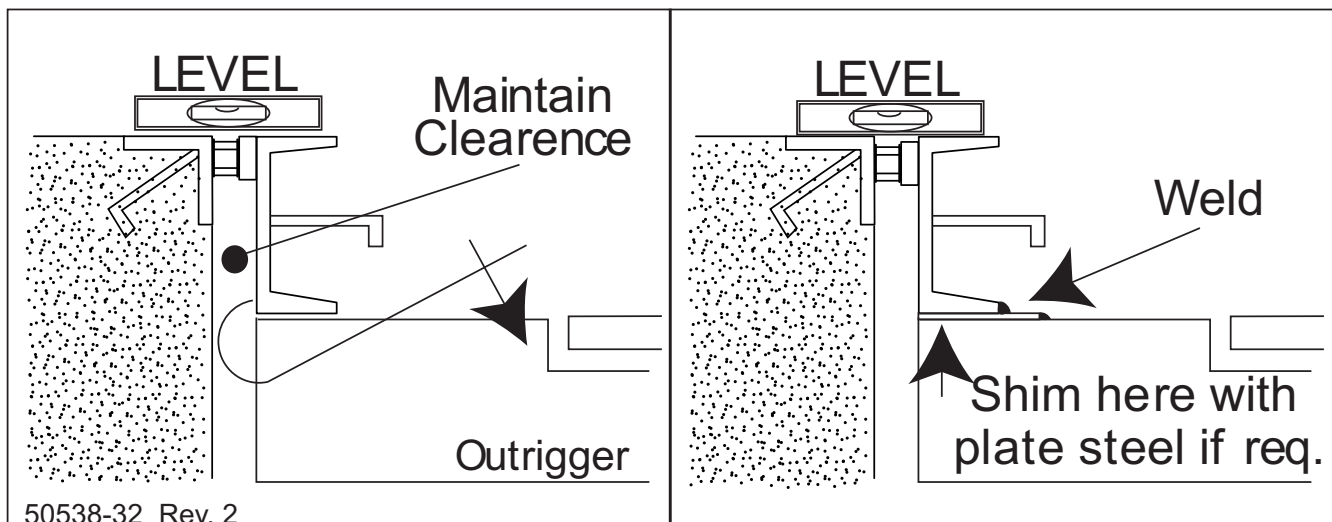

**3:** Pit coping irregularities may cause gaps between the deck coping and outriggers. Shim as needed with steel plate. Maintain proper spacing as shown, and weld the deck coping to the outrigger, including any steel plate shims as applicable. Continue until all pit wall deck coping has been installed.

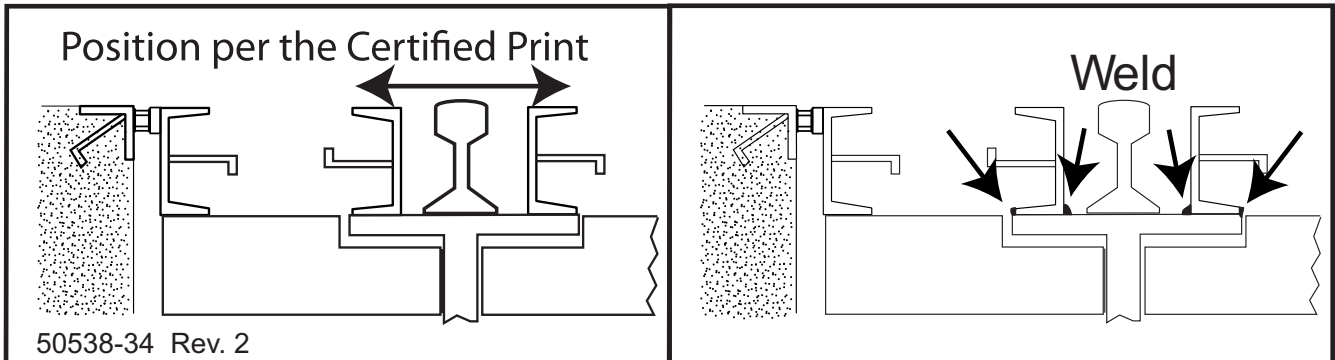

50538-34 Rev. 2

**4:** Layout the deck coping on the main beams beside each rail as shown. Position the deck coping to provide rail clearances per the certified prints. Ensure they are straight. Clamp and weld the deck coping as shown. Welds should be one (1) inch long, and at sixteen (16) inch intervals more if required.

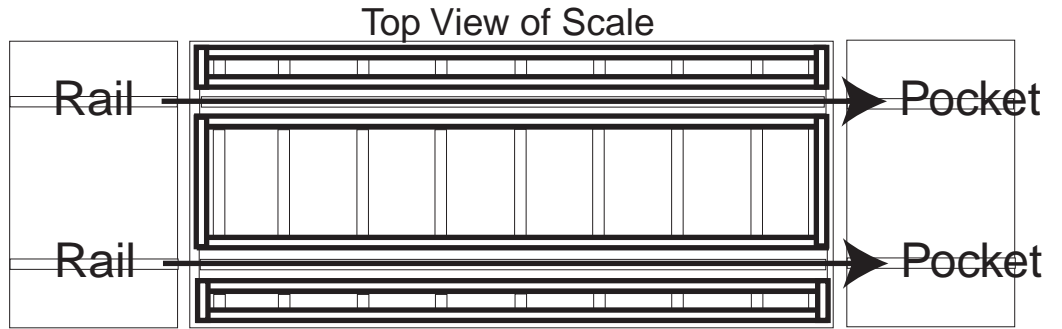

50538-33

**5:** At the twelve (12) corner junctures of the deck coping, and at all other points, ensure there are no gaps or openings through which redi-mix concrete can leak. Cut and weld steel plate to cover any gaps or openings as necessary.

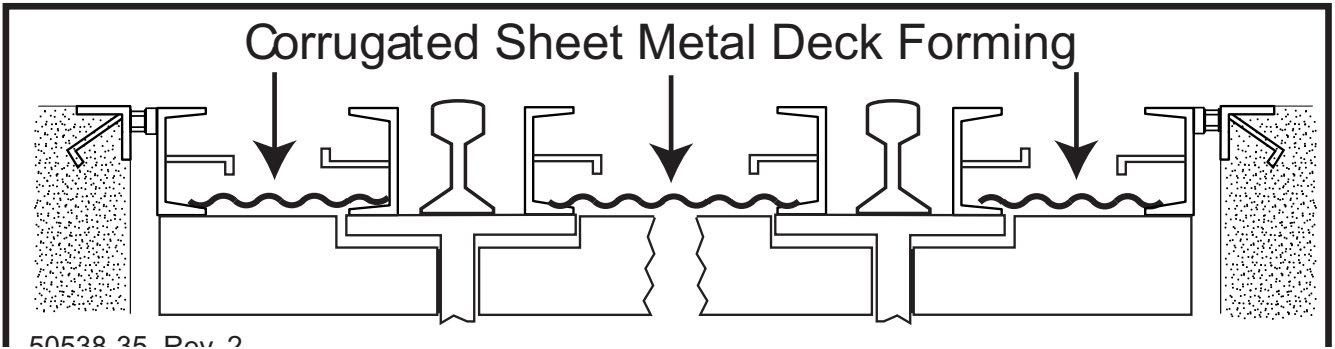

50538-35 Rev. 2

**6:** Corrugated steel sheets are used for deck forming, and can be purchased in a variety of different configurations, thickness, and dimensions. It is recommended to use steel galvanized sheets, 22 to 24 gauge, and 9/16 inches high. Cut the corrugation to fit tightly at the bottom flanges of the deck coping, and overlap the adjoining sheets by three (3) feet. Ensure all corrugation is resting on the lower flanges of the deck coping. If required, fasten the corrugation where needed to secure it into position.

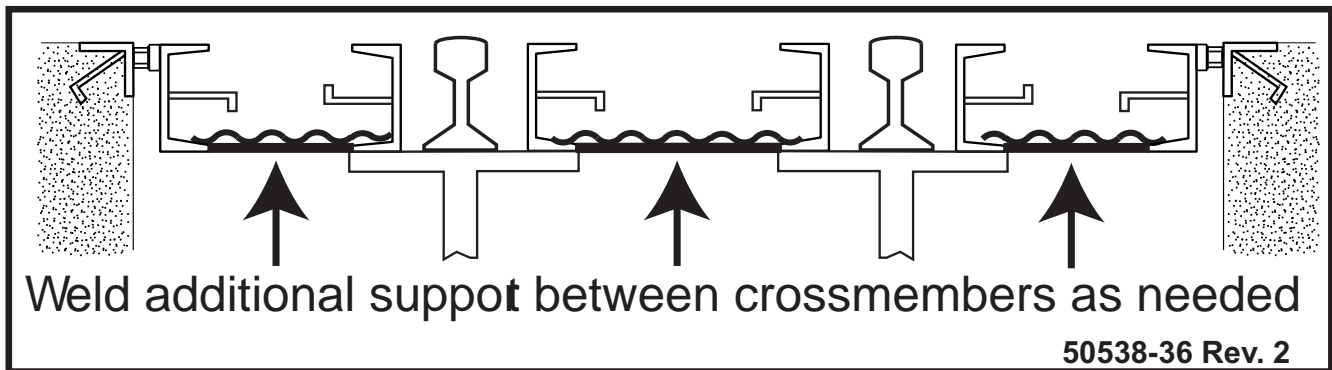

**7:** Additional supports are required (between the crossmembers and outriggers) to prevent the corrugation from collapsing when the redi-mix concrete is poured and floated. This support can be provided by welding flat steel plate or reinforcement rod as shown.

**8:** Install the manholes exactly as noted in the certified prints. Ensure they are placed in their correct positions on the corrugation, and are supported properly. Fill a large plastic bag with loose dry dirt or sand and place it in each manhole ring (this will keep the redi-mix concrete out of the ring). Place the covers onto both manhole assemblies.

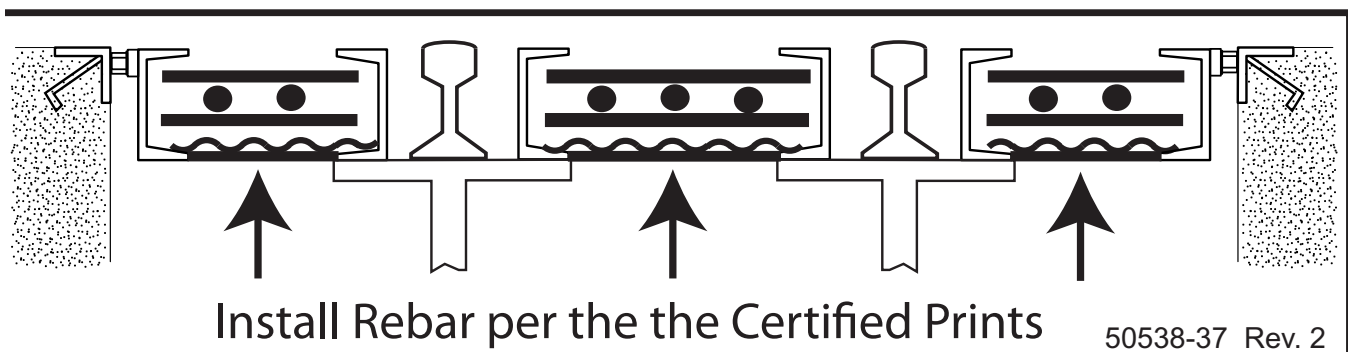

**9:** Install, block, and tie the rebar per the certified prints. Ensure the rebar is lifted from the corrugation to provide the specified concrete cover, per the certified prints.

**10:** Pour, float, edge, and broom finish the concrete mix.

All concrete workmanship shall be performed in accordance with the best practice as described by the American Concrete Institute.

Allow concrete to cure thoroughly. Do not use, or subject the deck to any traffic until the concrete has attained its ultimate compressive strength of 3000 psi after 28 days.

**NOTE:** The installation and finishing of poured concrete is best left to trained, experienced, and well equipped personnel.

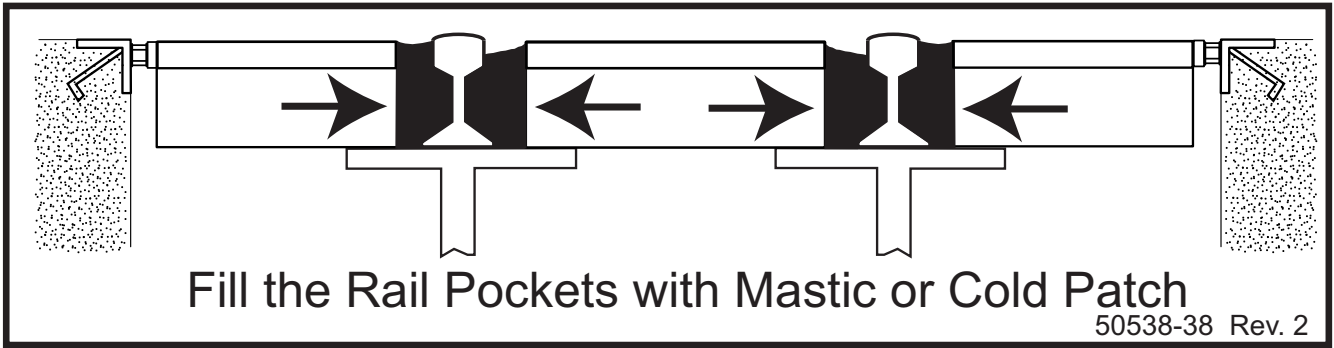

**11:** After the concrete has cured and the rail is installed, fill the rail pockets continuously with bituminous mastic or asphalt, except at the ends of the scale where clearance must be maintained between the approach and scale rail, and between the pit coping and scale deck coping.

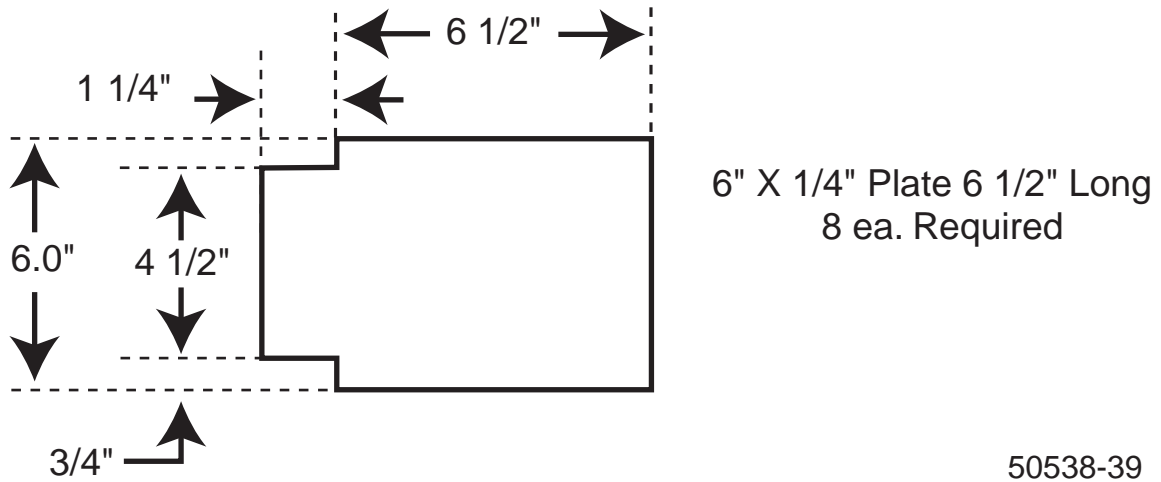

Shaping and welding steel plate to the end of the Rail pockets as shown above will provide a dam for the mastic at the ends of the rail pockets.

**12:** After the deck has cured, remove all welded coping spacer nuts. Open manholes and provide access by cutting the corrugation.

**2-U: Junction Box(s)**

The A.A.R. Combination Railroad Track / MTS Scale is shipped for installation to a 2500 Series Instrument. As part of that installation, there may be five (5) junction boxes to be installed in the pit. To provide mounting for these junction boxes, locate the following part that is shipped with the scale.

<b><u>Part #</u></b>	<b><u>QTY</u></b>	<b><u>Description</u></b>
55766	5	Bar, Junction Box; 3/4" X 1 1/4" (2 holes tapped 3/8-16).

The Junction Box bars can be welded to cross member at each load cell section. Place the Junction Box bars in a servicable location.

**2-V: Grounding:**

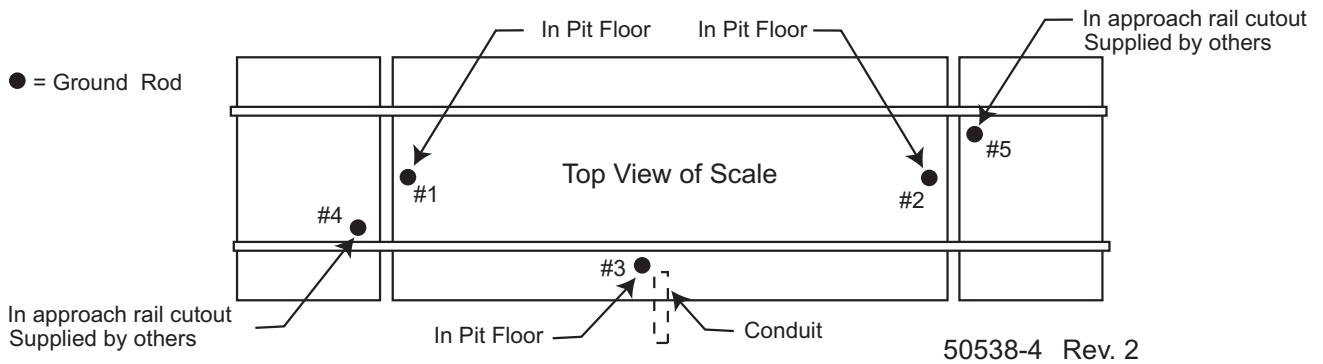

1: Clean #1, #2, and #3 ground rod end(s) with abrasive to assure a good electrical connection. Keep all ground straps untwisted, clear of standing water, with a drip loop, and as short as possible. Secure the strap to the ground rods with the provided clamp and coat with grease. Cover the connections to protect from condensation.

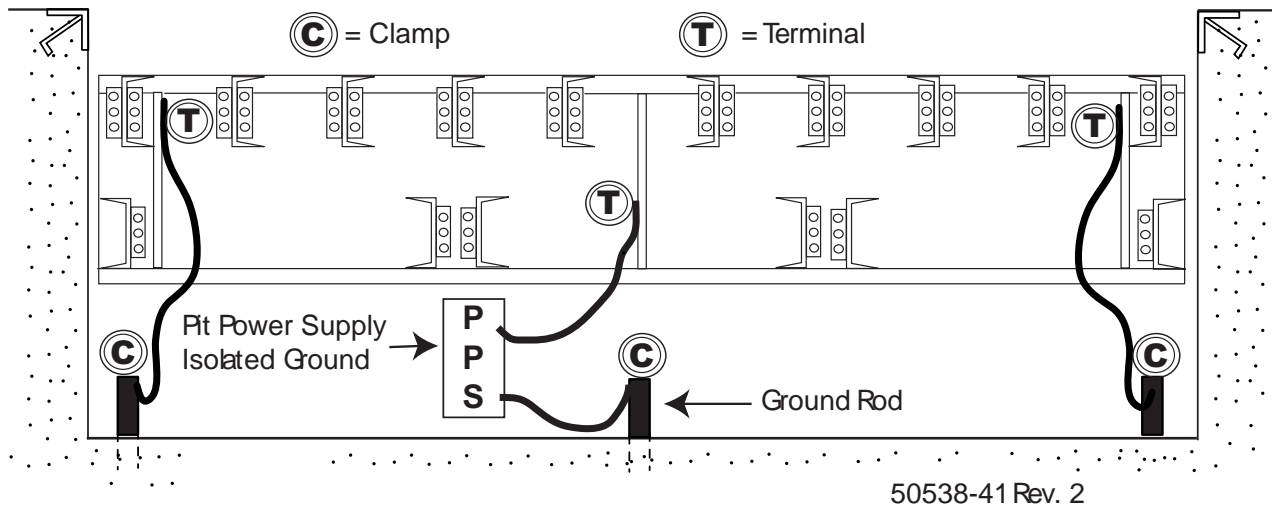

- 2:** Connections to the weighbridge are installed by drilling a hole in the welded flange (stiffener). Scrape / sand enough paint / coating away to make a good electrical connection and secure with the provided hardware.
- 3:** Connect the strap to the weighbridge steel using the provided set screw terminals and coat with grease AFTER the connection has been made.
- 4:** Ground rod #3 should be located near the interface conduit. It is used to connect to the isolated ground of the Pit Power Supply (PPS) Acc 2001-1 only.
- 5:** The Junction Box Plate MUST be connected to the weighbridge with a ground braid, or a conductor of not less than 10 AWG.

### **Section 3: Maintenance**

Inspect the Scale and its understructure on a regular basis to ensure:

- 1:** The approach rails and Scale rails remain securely in position and are properly aligned and fastened in place.
- 2:** The space between the deck edge, pit coping, and rails is clear and free of material which could jam the deck and cause inaccurate weights.
- 3:** The Scale Pit and understructure is clean and dry. Keep the pit and the understructure of the Scale as clean and as dry as possible. Any moisture problems should be addressed immediately to prevent steel deterioration. Structural steel should be wire brushed and painted as soon as rust appears.
- 4:** All Load Cell Support Assy's are clean and free of debris. Top Bearing Plate Assy's are centered on wear plate. Upper Flexure is clean and undamaged. All bolts are tight. Lower Flexure is clean and undamaged. Inspect Lower Button Closely and carefully for any surface cracks or other visible damage.
- 5:** Drains for the pit are clear and unblocked. Any installed automatic sump pump and discharge piping shall be in good working condition.
- 6:** The Check rods and spherical washer sets are in good condition, greased, and adjusted properly.
- 7:** All junction box wire gland nuts are securely tightened, and that nylon plugs are in place in any unused gland fittings.
- 8:** Secure the Junction Box Covers onto the unit using their latches.
- 9:** All excess cable is neatly coiled and tied up out of any possible accumulations of standing water.
- 10:** All cable entry and exiting points are finished with a drip loop.
- 11:** All ground rod connections are clean, tight, and greased to protect against corrosion.

**Section 4: Parts List**

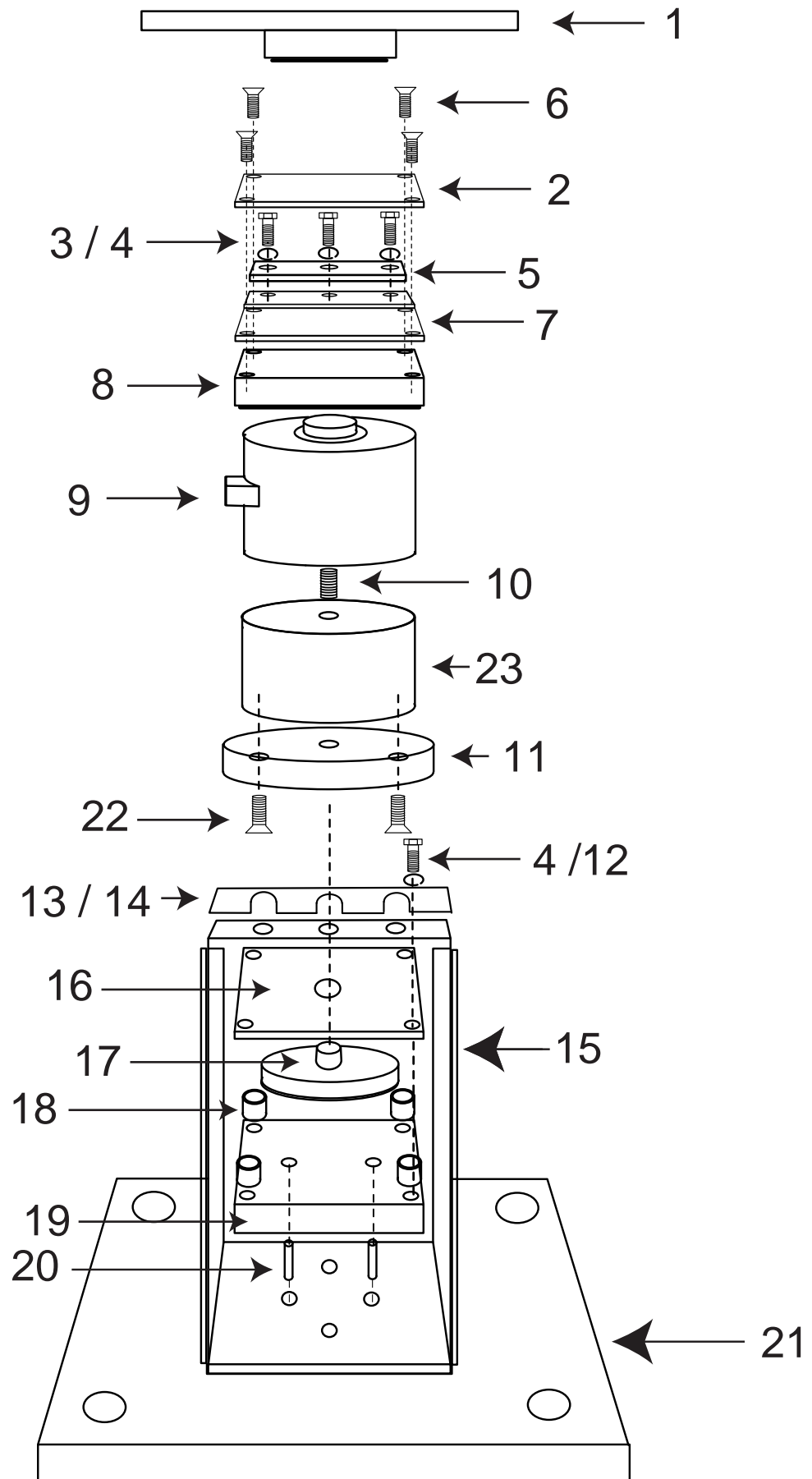

50538-42 B

#### **-Section 4: Parts List**

<b><u>Key #</u></b>	<b><u>Part#</u></b>	<b><u>Ref #</u></b>	<b><u>Description Qty</u></b>
1	58652	2-46715-1	Top Bearing Plate Assembly
2	12125	1-46694-1	Wear Plate
3	54367	127CS	1/2-13 x 1 1/4" Sc.Cap Hex Head
4	54769	305WA	1/2" Spring Lock Washer
5	58650	1-46695-1	Flexure Bar
6	54223	107MS	1/4-20 x 1/2" Flat hd screw Phil
7	12122	2-46691-1	Upper Flexure Assembly
8	58782	2-49930-1	Upper Button Bearing Assy
9	59156	3-43076-3	Load cell 200K
10	54380	129FSS	5/8-18 x 1 1/4" threaded rod
11	58662	2-48160-1	Lower Spacer
12	54370	128CS	1/2-13 x 1 1/2" Hex Bolt
13	12126	1-46696-1	Shim ( 0.027" THICK)
14	12127	1-46696-2	Shim ( 0.046" THICK)
15	58661	3-48159-1	Load cell Support Assembly
16	12128	1-46698-1	Lower Flexure
17	58664	1-48162-1	Lower Button
18	58663	1-48161-1	Pipe Spacer, Lower Flexure
19	58670	2-48278-1	Lower Bearing Plate
20	54380	129FSS	5/8-18 x 1 1/4" Hdless sock set screw, Cup pt
21	58671	2-48279-1	Base Plate
22	54394	132SS	5/8-18 X 1-1/4" Flat Head Screw
23	61940	91026	Adapters Pacer 6-1/2" 0 x 4-3/8" Tall

## **Parts Not Pictured:**

Part#	Description Qty
59600	Cut ¼" Steel Plates (2" X 2" Square)
59795	5/8-11 X 4" Chk Stand Leveling Screw
54591	¾-10 X 6" Base Plate Leveling Screw

## **Weighbridge Assembly Bolts**

54532	¾-10 X 3" Hex Bolt
54229	¾-10 X 3 ½" Hex Bolt A325 with Nut
54199	¾ -10 X 2 ¼" Hex Bolt with Nut.
54217	¾-10 X 3" Hex Bolt A325 with Nut
54402	1" X 3 ½" Hex Bolt A325 with Nut

## **Misc Hardware**

54342	1 ½-6 Hex Nut (Check Rods)
54897	1 ½-6 Jam Nut (Check Rods)
58617	1 ½ Spherical Washer Set (Check Rods)
55766	¾" X 1 ¼" X 5" Bar, J Box

## **Grounding Kit Components**

60811	¾" X 8' Ground Rod, Copper Plated,
65061	Clamp, Ground Rod
79385	Set Screw, Ground Braid Clamp
11296	5/8" ID, #8 AWG Braided Ground Strap,
58618	Ground Rod Cap, PVC
79386	5/16-18 X 1 ½" Hex Cap Screw
54224	5/16-18 Hex Nut
54760	5/16" Spring Lock Washer

## **Appendix I: Recommended Tools & Equipment:**

<b><u>QTY</u></b>	<b><u>DESCRIPTION</u></b>
2 EA	MASON LINE
1 EA	25 FOOT TAPE MEASURE
1 EA	100 FOOT TAPE MEASURE
1 EA	TRANSIT
1 EA	PRECISION LEVEL (Starrette Model 98 Mechanics Level, 6 inch long model)
1 EA.	TORQUE WRENCH OF SUITABLE CAPACITY
1 EA	THREAD FILE; STANDARD THREAD SIZES OF 10, 8, 7, 6.
1 EA	ELECTRIC DRILL / VARIABLE / 1/2" CHUCK SIZE
1 EA	1 1/4" & 1 1/2" WOOD DRILL BIT
1 EA	WOOD HAND SAW
1 EA	CARPENTERS CLAW HAMMER
4 EA	5 GALLON BUCKETS, WITH HANDLE
2 EA	LARGE & SMALL TROWEL S
2 EA	1 1/4" STRUCTURAL WRENCH WITH OFFSET HEAD (TO FIT 3/4-10 X 3 1/2" LONG A325 BOLTS)
1 EA	3/4" SOCKET SET
1 EA	1/2" OR 3/4" ELECTRIC IMPACT WRENCH
1 EA	1 1/4" HARDENED DEEP 6 POINT IMPACT SOCKETS
2 EA	24" ADJUSTABLE WRENCH (2 7/16" MAX. OPENING)
6 EA	6" HEAVY DUTY C-CLAMP, SUITABLE FOR WELDING
2 EA	8" HEAVY DUTY C-CLAMP, SUITABLE FOR WELDING
1 EA	STEEL CARPENTERS SQUARE
1 EA	HEAVY DUTY RIGHT ANGLE ELECTRIC GRINDER WITH 7" DEPRESSED CENTER STONE.
1 EA	AC/DC 200 AMP ARC WELDER / IF GASOLINE DRIVEN, INCLUDE A GAS CAN. BOTH WIRE LEADS MUST BE LONG ENOUGH TO REACH EVERY AREA OF THE SCALE
1 EA	OXYGEN / ACETYLENE CUTTING TORCH SET
2 EA	36" CROW BAR / GOOSENECK BAR
2 EA	24" CROW BAR / GOOSENECK BAR
1 EA	SHORT HANDLED 4 LB SLEDGE HAMMER
1 EA	LONG HANDLED 5 LB SLEDGE HAMMER
1 EA	ADJUSTABLE SQUARE
1 EA	2 FOOT LEVEL, GENERAL PURPOSE
2 EA	20 TON CAPACITY JACKS
1 EA	HAND TRUCK
2 EA	WIRE BRUSHES
1 EA	5 LB. GREASE
6 EA	CANS OF SPRAY PAINT, COLOR = RED OXIDE PRIMER

## **Appendix II: Required at the Jobsite:**

117 VAC Electric Power (Extension cords as needed)

Water

Suitable crane(s)

Rigging (I.E. Straps, 4 leg drops, etc.)

NOTE: The weight capacity of all lifting and rigging equipment must be suitable for their intended use.

## **Appendix III: Materials:**

Grout shall be precision, packaged dry, non-metallic, hydraulic, non-shrink, and non-gaseous. Grout shall meet or exceed ASTM C-1107 and Corps of Engineers CRD-C621.

Grout shall be bleed free and attain a minimum of 8000 psi compressive strength in 28 days at flowable consistency.

Grout MUST be mixed to a flowable consistency as specified by the grout manufacturer.

Quantity required will vary according to pier heights. Projected amount is 3 bags per load cell base plate, and 2 bags per checking stand at 40lb per bag.

NOTE: Pier heights other than those indicated on the certified prints will affect the quantity required.

Wood for forming base plates and checking stands. Select unfinished pine, 1 1/2" to 2" wide X 12 feet long. Project quantity is one stick per base plate, and one stick per check stand.

Drywall screws suitable for constructing and securing wood forms.

50 lbs of welding rod, 1/8" X 14" rods, AC/DC, all purpose, Type 7014.

Wood blocking and cribbing material, suitable for supporting the weighbridge, and the 20 ton jacks. Sufficient quantity to provide a safe, stable support from the pit floor to the bottom of the main I-beams. Shipping weights for these scales range from 36,500 lbs to 50,000 lbs.

Materials and equipment for mixing the grout and water to a suitable consistency, and delivering it to each base plate and checking stand.

Grease: NLGI #2, Water resistant, Anti-wear Grease such as CRC Super White.

## **Appendix IV: Torque Values Chart**

All Values are Pounds (LB).

SIZE	GRADE 2 LUBED	GRADE 2 DRY	GRADE 5 LUBED	GRADE 5 DRY	GRADE 8 LUBED	GRADE 8 DRY
1/4-20	49 in	65 in	75 in	100 in	107 in	143 in
5/16-18	101 in	134 in	157 in	210 in	220 in	305 in
3/8-16	15 FT	20 FT	23 FT	31 FT	32.5 FT	44 FT
7/16-14	24 FT	30 FT	37 FT	50 FT	53 FT	70 FT
1/2-13	36.5 FT	49 FT	57 FT	75 FT	80 FT	107 FT
9/16-12	53 FT	70 FT	82 FT	109 FT	115 FT	154 FT
5/8-11	73 FT	97 FT	113 FT	151 FT	159 FT	211 FT
3/4-10	129 FT	173 FT	200 FT	266 FT	282 FT	376 FT
7/8-9	125 FT	166 FT	321 FT	430 FT	454 FT	606 FT
1-8	187.5 FT	250 FT	482.5 FT	640 FT	680 FT	900 FT

## **Appendix V: Tolerances:**

Load Cell Base Plates, level within 1/64" per Foot  
Upper bearing Plates, level within 1/64" per Foot  
Check Stands, level within 1/64" per Foot  
Check Rods, level within 1/100" per Foot

## **Appendix VI: Load Cell Specifications:**

Capacity: 200,000 LB.  
Height: 7 1/4" Inches High.  
Input Resistance: 450.50 Ohm  
Output Resistance: 482.64 Ohm  
Isolation Resistance: >=5000 Meg Ohm (measured with 50 volts DC)  
Calibration: 2.0 mV/V  
Cable Length: 15 ft.

Wiring: Excitation (+) = Green  
Excitation (-) = Black  
Output (+) = White  
Output (-) = Red  
Shield = Transparent

## **APPENDIX VII: Concrete & Slump Testing:**

Concrete is produced from the mixing of sand (fine aggregate), stone (coarse aggregate), cement and water. The water combines with the cement to form a fluid paste often referred to as "plastic". The paste is combined with the sand and stone to make a workable "plastic" concrete that can be poured, shaped, smoothed, and molded. The plastic concrete then hardens around the sand and stone forming a solid mass. Concrete in its plastic state can be formed into structures such as pavements, walls, or footings. When the plastic concrete hardens, the structures formed can then support the anticipated loads.

The reaction of water with cement is called hydration. The water to cement ratio is an important factor in the ultimate strength of the concrete and its subsequent load carrying ability. The lower this ratio is, the tighter the microscopic crystals of concrete, and the stronger the concrete will be. Fewer shrinkage cracks from excess water will also result from this low ratio.

For a given amount of cement, a smaller quantity of water will produce a higher strength concrete. Too small a quantity of water, however, will not allow for adequate mixing of the sand and stone, and will also make the concrete difficult to "work" and to form, which in turn will produce a lower strength concrete.

The amount of water in a particular concrete mixture is thus carefully selected to balance the desired strength of the concrete. Whether a "soupy" mix, or "firm" mix, the ability of the concrete to be shaped, worked, and placed is called fluidity. The slump test is a quality control measure of the fluidity of the concrete mixture.

The procedure for the slump test is covered in ASTM (American Society for Testing & Materials) Document C-143 from a sample of concrete obtained per ASTM C-172. The slump is measured in inches. The measured slump is then compared to the desired specifications.

The equipment for the slump test is usually a metal cone, a metal base plate and a metal rod. The "cone" is 12 inches in height, 4 inches in diameter at the top, and 8 inches in diameter at the bottom. The slump test must be performed within 2 1/2 minutes after obtaining the sample.

- 1: The cone, base plate, and rod are moistened with water.
- 2: The cone is placed on the base plate with the 8" opening at the bottom.
- 3: The cone is filled in three (3) equal layers.
- 4: Each layer is rodded 25 times to settle the concrete, before the next layer is added.
- 5: The cone is then pulled straight up and off of the sample. The cone must come off within 3-7 seconds for an accurate test, per ASTM standards.
- 6: When the cone is removed, the concrete mixture "slumps" down. It is then measured to determine how far down it has slumped, and compared to specification.

The slump test is a direct measure of the amount of water in the mixture, unless ADMIXTURES are added. Admixtures are liquid chemicals added to concrete to make it easier to place without the reduction in strength adding water would cause. Admixtures of this type are known as "plasticizers" or "water reducers", and adding them to the mixture will either make the concrete mix more "plastic" with the same amount of water, or allow the concrete to have the same "plasticity" with a smaller amount of water (increasing strength). Testing and ensuring the slump specification for concrete is correct will enable the concrete mixture to have the strength and placability the designer requires it to have.

### **APPENDIX VIII: About the AAR:**

The American Association of Railroads (AAR) is one of the nation's oldest and most respected trade associations and represents the major freight railroads in the United States, Canada and Mexico. Amtrak and some commuter railroads are also members of the AAR. In addition, the AAR has two categories of associate members, one for smaller railroads and a second for railway suppliers and others with an interest in railroads. The AAR serves as the joint representative of its individual members in matters requiring cooperative handling to better enable railroads to be an efficient, safe, inter-linked system. It is governed by a board of directors that includes the CEO of each Class I railroad in the United States. Amtrak, smaller railroads, Mexican railroads and the Railway Association of Canada are also represented on the AAR Board. One CEO serves as AAR Chairman for a one-year term which rotates among the Class I railroads.

### **About AREMA**

The American Railway Engineering and Maintenance-of-Way Association (AREMA) was formed on October 1, 1997, as the result of a merger of three engineering support associations, namely the American Railway Bridge and Building Association, the American Railway Engineering Association and the Roadmasters and Maintenance of Way Association, along with functions of the Communications and Signal Division of the Association of American Railroads.

The rich history of the predecessor organizations, each having over 100 years of service to the rail industry, is the legacy of AREMA.

### **About the American Railway Engineering Association**

At the suggestion of Railway Age magazine, a meeting was held in Chicago on October 21, 1898, to organize a forum for the development and study of recommended practices for the newly-integrated standard-gauge North American railway network. This led to a meeting in 1899 in Buffalo, New York, to adopt a constitution and establish a permanent organization named the American Railway Engineering Association (AREA). From its inception, the AREA dealt with the many engineering challenges through standing technical committees. Five of those committees; ties, rail, track, buildings and yards & terminals continued intact continuously from 1899 until the merger and still continue under AREMA functional groups. In 1905, AREA issued its first Manual of Recommended Practices. Its name was changed to the Manual of Railway Engineering in 1970 and is updated annually by the technical committees. The manual, which is now also available on CD-ROM, will continue under AREMA.

**APPENDIX X: Special Product Applications -- Short Load Cell Assembly**

