

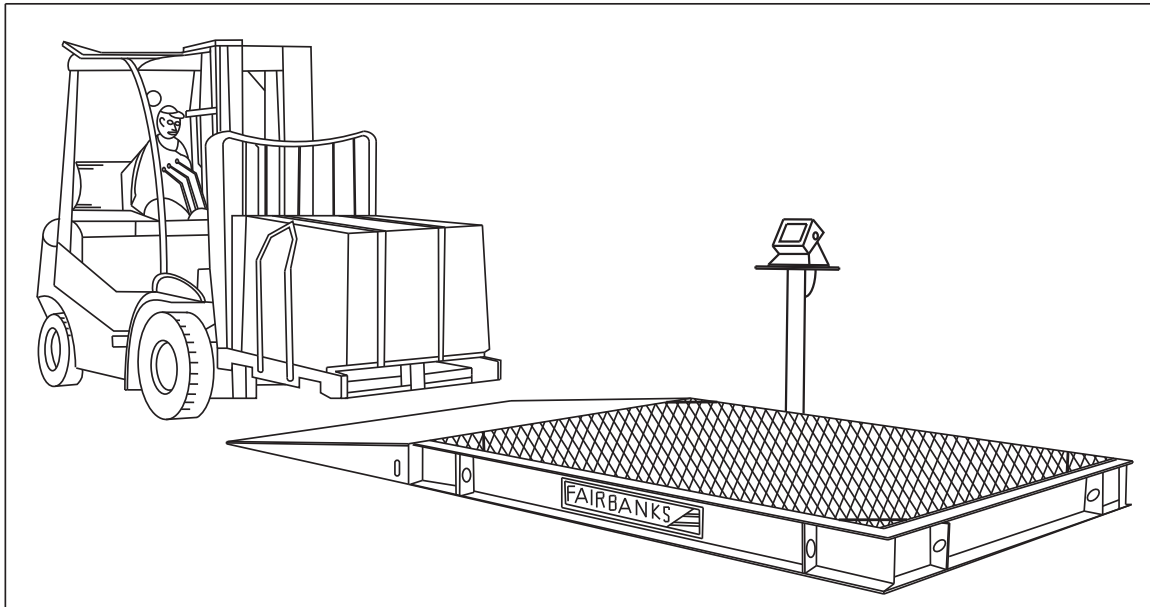

Aegis Xtreme-Duty Floor Scale



Amendment Record
AEGIS XTREME-DUTY FLOOR SCALE
Document 51206

Manufactured by Fairbanks Scales Inc.
821 Locust
Kansas City, Missouri 64106

Created	9/08	Created Document
Revision 1	11/08	Document Release

Disclaimer

Every effort has been made to provide complete and accurate information in this manual. However, although this manual may include a specifically identified warranty notice for the product, Fairbanks Scales makes no representations or warranties with respect to the contents of this manual, and reserves the right to make changes to this manual without notice when and as improvements are made.

Fairbanks Scales shall not be liable for any loss, damage, cost of repairs, incidental or consequential damages of any kind, whether or not based on express or implied warranty, contract, negligence, or strict liability arising in connection with the design, development, installation, or use the scale.

© Copyright 2008

This document contains proprietary information protected by copyright. All rights are reserved; no part of this manual may be reproduced, copied, translated or transmitted in any form or by any means without prior written permission of the manufacturer.

Table of Contents

SECTION 1: GENERAL INFORMATION	7
1.1. Introduction	7
1.1.1. Specifications.....	7
1.1.2. Accessories.....	9
SECTION 2: GENERAL SERVICE POLICY.....	10
2.1. General Service Policy	10
2.1.1. Service Technician's Responsibilities.....	11
2.1.2. Users' Responsibility	11
SECTION 3: SCALE INSTALLATION.....	12
3.1. Conferring with Our Client	12
3.2. Standard Installation Steps.....	14
3.2.1. Unpacking.....	15
3.2.2. Positioning the Scale	16
3.2.3. Positioning Steps.....	17
3.2.4. Installing the Platform	18
3.2.5. Wiring the Junction Box.....	20
3.3. Installing Accessories	21
3.3.1. Ramp Installation	21
3.3.2. Pillar Installation Steps	22
SECTION 4: SERVICE & MAINTENANCE	23
4.1. General Troubleshooting	23
4.2. Scale Platform Troubleshooting	24
4.2.1. Scale Platform Testing.....	24
4.2.2. Load Cell Testing.....	24
4.2.3. Load Cell Replacement Steps.....	25
SECTION 5: PARTS.....	26
5.1. Parts Lists #107979 – 5' x 5' X8", 20K	26
5.2. Parts List #106966 – 6' X 8' X 8", 40K.....	26
5.4. Parts Diagram.....	27
5.5. Accessory Part Numbers	28
5.5.1. Aegis Xtreme-Duty Ramp Assembly	28
5.5.2. Aegis Xtreme-Duty Pit Frame Assembly	28
5.5.3. Mild Steel Stand-alone Instrument Pillar	28
5.3. PLATFORM MODEL MATRIX.....	29

Section 1: General Information

1.1. INTRODUCTION

The **Aegis Xtreme-duty Scale** is an extremely rugged floor scale, designed for high capacities and a wide variation of dimensional sizes. This is because of the additional I-beam supports under the platform that run both along the scale's "X" and "Y" axis.

It has an extremely low-profile design. The scale's floor height is **8 or 9 inches**, depending on the capacity.

The **Aegis Xtreme-duty Scale** is designed for applications with high load concentrations.

- *General Industrial*
- *Heavy-Duty Industrial*
- *Extremely large fork lifts*
- *Large freight containers*
- *Warehousing*

1.1.1. Specifications

Feature	Description
Standard Platform Sizes	4' x 4' thru 6' x 8'
Custom Platform Sizes	4' x 2' thru 12' x 15'
Platform Height	8" to 9" Diamond Tread
Scale Capacities	<ul style="list-style-type: none">• 20,000, 40,000, and 60,000• 2,500 up to 95,000
Overload Capacity	150%
Point Loading	100%
Endloading	100%
Temperatures	<ul style="list-style-type: none">• Operating: 10°C to 40°C (14°F to 104°F)• Storage: -20°C to 70°C (14°F to 158°F)
Humidity	10 to 100%
Accuracy	Meets or exceeds Handbook 44 tolerances
Load Cell Excitation	5 to 15 VDC
Grounding	Less than 3 Ohms to True Earth Ground

1.1.1. Specifications, Continued

Feature	Description
Scale Construction	<ul style="list-style-type: none"> Type A36 carbon steel Deck plate – ¼” to ½” Full I-beam support Diamond Tread
Junction Box	<ul style="list-style-type: none"> Watertight Analog Stainless Steel NEMA 4X
Load Cells	<ul style="list-style-type: none"> Four (4) Rocker Column Design IP69K “True” Hermetically Sealed 17-4 ph Stainless Steel 15,000 to 50,000 Capacity Combined Error -- +/- 0.02% of Rated Capacity
Interface Cable	31’ PVC Jacketed
Approvals	<ul style="list-style-type: none"> FM Approved NTEP Approval CC# 07-097 (for 6,000 divisions) Load Cell NTEP Approval CC# 07-037



1.1.2. Accessories

Available modifications and accessories include the following:

- *Aegis Xtreme-Duty Ramp*
- *Stand-alone Instrument Pillar*
- *Flush-Grade Pit Frame*

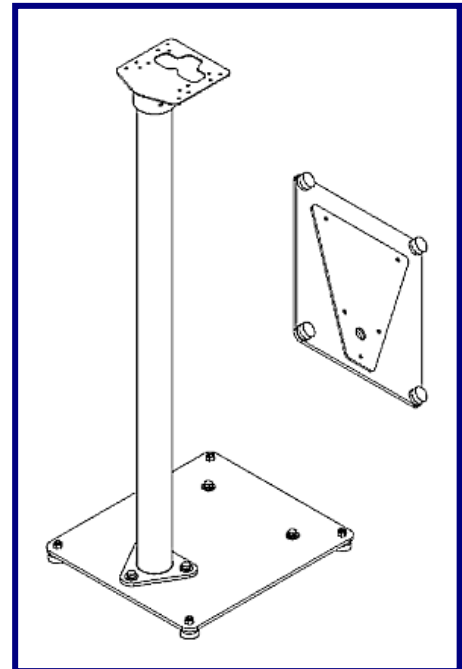

Section 2: General Service Policy

2.1. GENERAL SERVICE POLICY

Prior to installation, ***always*** verify that the equipment satisfies the customer's requirements as supplied, and as described in this manual.



If the equipment cannot satisfy the application and the application cannot be modified to meet the design parameters of the equipment, **the installation should NOT be attempted.**

It is **the customer/operator's responsibility** to ensure the equipment provided by Fairbanks is operated within the parameters of the equipment's specifications and protected from accidental or malicious damage.

WARNING!

Absolutely NO physical, electrical or program **modifications** other than selection of standard options and accessories can be made by customers to this equipment

Repairs are performed by Fairbanks Scales Service Technicians and Authorized Distributor Personnel ONLY!

Failure to comply with this policy voids all implied and/or written warranties

2.1.1. Service Technician's Responsibilities

- ✓ All electronic and mechanical calibrations and/or adjustments required for making this equipment perform to accuracy and operational specifications are considered to be part of the original installation.

- They are included in the installation charge.
- Only those charges which are incurred as a result of the equipment's inability to be adjusted or calibrated to performance specifications may be charged to warranty.



- ✓ The equipment consists of printed circuit assemblies which must be handled using ESD handling procedures, and must be replaced as units.
 - Replacement of individual components is not allowed.
 - The assemblies must be properly packaged in ESD protective material and returned intact for replacement credit per normal procedures.

2.1.2. Users' Responsibility

- ✓ **Absolutely no physical, electrical or program modifications other than selection of standard options and accessories are to be made to this equipment.**



Section 3: Scale Installation

3.1. CONFERRING WITH OUR CLIENT

- The technician must be prepared to recommend the arrangement of components which provide the most efficient layout, utilizing the equipment to the best possible advantage.
- Assist the customer in selecting a site which allows easy access to and from the scale, ensuring enough area for straight and level approaches, if applicable.
 - The site needs good drainage away from the scale, elevated enough so the surrounding areas ***drain away from the scale.***
 - Obtain all the necessary permits and licenses prior to beginning construction.
- Explain and review the warranty policy with the customer.

The installing technician is responsible that all personnel are fully trained and familiar with the equipment's capabilities and limitations before the installation is considered complete.

- All electrical assemblies must be returned intact for replacement credit using the standard procedures.
- At the time of installation, all electronic and mechanical adjustments are considered to be part of the installation, and are included in the installation charge(s).
- The AC receptacle/outlet shall be located near the Indicator and easily accessible.
- Electrical connections other than those specified may not be performed.

★ ★ IMPORTANT INSTALLATION NOTICE ★ ★

- All load cells, load cell cables and interconnecting cables used to connect all scale components shall be located **a minimum of thirty-six (36") inches distance away** from all single and multiple phase high energy circuits and electric current carrying conductors.
- This includes digital weight indicators, junction boxes, sectional controllers, and power supplies.
- This includes any peripheral devices, such as printers, remote displays, relay boxes, remote terminals, card readers, and auxiliary data entry devices.
- Also included is the scale components themselves, such as 120 volt AC, 240 volt AC, 480 volt AC and electric supply of higher voltage wiring runs and stations, AC power transformers, overhead or buried cables, electric distribution panels, electric motors, florescent and high intensity lighting which utilize ballast assemblies, electric heating equipment, traffic light wiring and power, and relay boxes.
- All scale components, including digital weight indicators and peripheral devices are not designed to operate on internal combustion engine driven electric generators and other similar equipment.
- **Electric arc welding** can severely damage scale components such as digital weight indicators, junction boxes, sectional controllers, power supplies, and load cells.

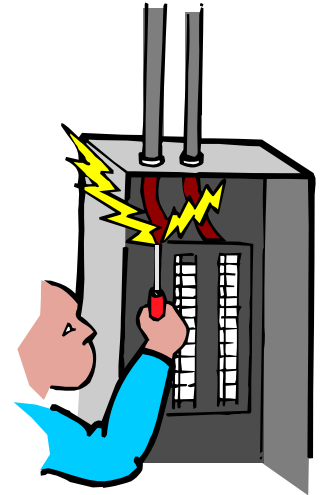

NOTE: For additional information, please contact your **Fairbanks Scales Service Representative.**

3.2. STANDARD INSTALLATION STEPS

The **Aegis Xtreme-Duty Scale Platform** is shipped **fully assembled and wired**. The standard scale installation consists of the following steps.

- **Unpack** the Scale, and any components.
- Selecting the best Platform **Site Location**.
- **Connect lifting straps** or chains to the lifting lugs on the sides of the platform, then **move it** to the designated site using a crane.
- Install the **Ramps** (if applicable).
- **Level** the Platform.
- Install and wire the **Instrument** to the Platform.
- **Adjust and Calibrate** the Scale according to the appropriate Indicator Service Manual.



3.2.1. Unpacking

Follow these guidelines when unpacking all equipment.

- ✓ Check in all components and accessories according to the customer's order.
- ✓ Remove all components from their packing material, checking against the invoice that they are accounted for and not damaged.
 - Advise the shipper immediately, if damage has occurred.
 - Keep the shipping container and packing material for future use.
 - Order any parts necessary to replace those which have been damaged.
 - Check the packing list.

The **CUSTOMER** is the **receiving party** if the equipment was **shipped to the Customer's address**.

FAIRBANKS is the **receiving party** if the equipment was **shipped to the Fairbanks Service Center**.

- ✓ Collect all necessary installation manuals for the equipment and accessories.
- ✓ Open the equipment and perform an inspection, making certain that all hardware, electrical connections and printed circuit assemblies are secure.
- ✓ Do not reinstall the cover if the final installation is to be performed after the pre-installation checkout.
- ✓ Do not load the platform if there is any evidence of damage to the platform or supporting structure.



NOTE: It is the **owner's responsibility** to document, notify, and follow-up regarding shipping damage with the carrier.

3.2.2. Positioning the Scale

Position the Scale with these points in mind:

- ✓ Use the proper lifting equipment to position and place the scale.
- ✓ The scale is to be placed on a flat, solid, level surface, one that fully supports the weight of the platform plus a full capacity load.
- ✓ The smooth surface must be within 1/8", and on a level plane, within 1/4" across both the length and width of the platform.
- ✓ The four corners of the Platform must rest solidly on the surface, and not rock. Irregular bumps and foreign material under the Platform can cause an "out-of-level" condition, which will affect the weight accuracy.
- ✓ Platform vibrations may also affect the weighing accuracy. Wherever possible, locate the platform as far away from heavy, low frequency vibrations as much as possible.
- ✓ Do not load the platform if there is any evidence of damage to the platform or supporting structure.
- ✓ Ease of access is very important. Allow plenty of room for maneuvering a fork lift.
- ✓ Reading the Indicator is also important to workers, so place it in a very visible position.
- ✓ When installing the Scale and Indicator in an outdoor location, set it up so the snow, ice accumulation, rain and other conditions do not affect the platform operations.

3.2.3. Positioning Steps

1. Position the Scale into its final location.
2. Place the hooks of the straps or chains into the specific lifting points of the Scale.
 - The straps or chains should be long enough to form a minimum **45° angle** with the platform while lifting.



To lift and move the Platform, place strap hooks into brackets on each side of it, and also into each hole of the ramp.

3. Place the platform in the desired location.
 - The platform should be made stable and level.
 - Shims are not included with the platform and must be supplied locally as needed.

3.2.4. Installing the Platform

1. Remove the four (4) triangular cover plates, found on each corner.
2. Remove the nut from the shipping bolts in each corner.



3. Drill and secure the platform using the supplied $\frac{3}{4}$ " **wedge anchors**.
4. Adjust the checking bolts to a **$\frac{1}{16}$ "** to **$\frac{1}{8}$ "** clearance.



3.2.4. Installing the Scales, Continued

5. Verify that the platform is plumb, square and level.
 - *If Ramps are to be installed, do it at this time.*
6. Replace the nut on the shipping bolt, then loosen it two (2) full threads.
7. Replace the four (4) triangular cover plates, found on each corner.
8. Calibrate the unit according to the appropriate indicator service manual.

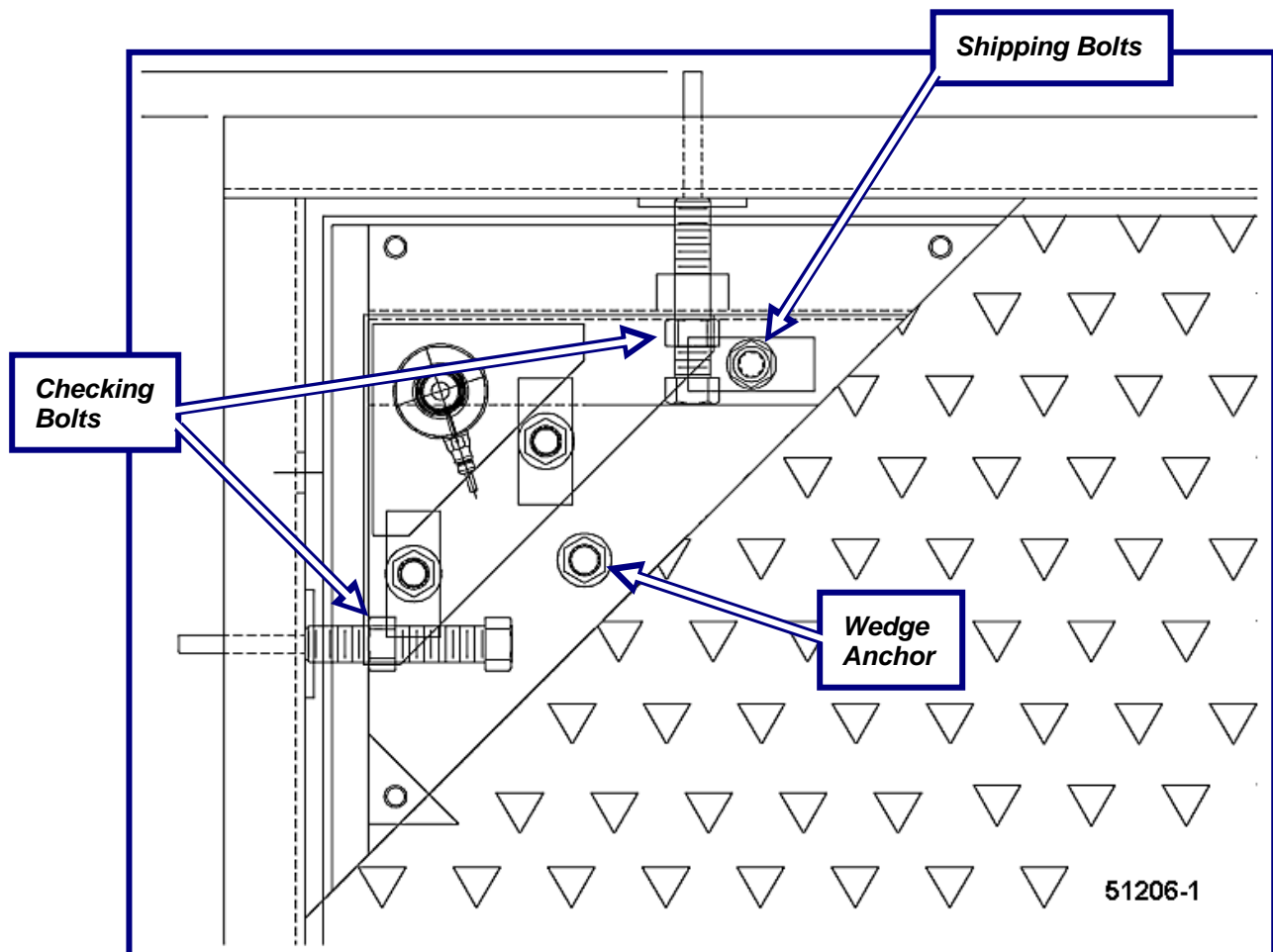

3.2.5. Wiring the Junction Box

Load Cells are preinstalled, plumbed, and pre-wired to the Junction Box at the factory, prior to shipping.

- Dip Switches are **not set**.
 - Interconnecting cables are **not installed**.
1. Open the platform access cover, then the junction box cover.
 2. Loosen all gland bushing nuts.
 3. Wire the Indicator to Junction Box according to the chart below.
 4. Follow the indicator installation manual to properly connect it with the platform.
 5. Tighten all gland bushing nuts.

IMPORTANT NOTE: Leave the Junction Box Cover **off** until all corner adjustments are completed.

WIRE COLOR	FUNCTION
Red	(-) Signal
White	(+) Signal
Black	(-) Excitation
Green	(+) Excitation
Yellow	Ground



3.3. INSTALLING ACCESSORIES/MODIFICATIONS

Listed below are the standard **Aegis Xtreme-Duty Scale Accessories**.

- *Aegis Xtreme-Duty Ramp*
- *Intrinsically Safe Controllers*
- *Flush-Grade Pit Frame*
- *Stand-alone Instrument Pillar*
- *Smart Sectional Controllers*
- Intalogix Technology (QMB)



3.3.1. Ramp Installation

The ramps are optional, and used different ways in varied applications.

- Each ramp has two (2) bolt down tabs, one on each side.
1. Place the ramp against the platform frame
 - The ramp’s slot is fits inside the scale’s lifting point.
 - Level and stabilize the ramp against the platform.
 - Shims are not included with the ramps and must be supplied.
 2. Drill and anchor the ramp(s) using the supplied **3/4” wedge anchors**.
 - Up to four (4) ramps can be installed on the **Aegis Xtreme-duty Scale**, one on each side.

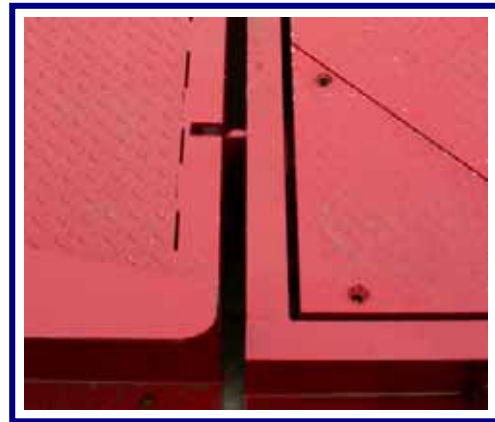

3.3.2. Pillar Installation Steps

1. To remove the Top Plate, loosen the **three (3) one quarter inch (1/4") Allen Screws**.
2. Carefully run the Interface Cable into the bottom Access Hole, up through the Pillar, and then thread it out through the top Access Hole.
 - Allow extra cable slack to accommodate the Instrument wiring.
3. Replace the Top Plate, then secure it into position using the **one eighth inch (1/8") Allen Wrench**.
4. Install the Instrument Top Bracket, secure it with the supplied hardware
5. Connect the Interface Cable to the Indicator.
 - Refer to the appropriate instrument service manual for correct wiring information.



Section 4: Service & Maintenance

4.1. GENERAL TROUBLESHOOTING

From the following chart, identify the symptom(s) and cause(s) of each malfunction, solving each issue with an appropriate solution.

SYMPTOM	CAUSE	SOLUTION
Displays stay at zero	<ol style="list-style-type: none">1. Load Cell connections faulty.2. Instrument faulty.3. Faulty/bad Load Cell(s).	<ol style="list-style-type: none">1. Cable replacement.2. Service Instrument.3. Test and replace the Load Cell(s) as shown in Section 4.2.3.
Erratic Weights	<ol style="list-style-type: none">1. Foreign object around load cells, ramps, or under platform.2. Excessive vibration near platform.3. Instrument faulty.4. Platform not level within $\frac{1}{4}$" (3.0°).5. Surface not smooth enough (within $\frac{1}{8}$").6. Faulty/bad Load Cell(s).	<ol style="list-style-type: none">1. Clear the area.2. Remove the vibration source.3. Service Instrument.4. Level the platform surface.5. Find a smoother surface for the platform.6. Test and replace the Load Cell(s) as shown in Section 4.2.3.
Inaccurate Weights	<ol style="list-style-type: none">1. Instrument out of span.2. Instrument not properly adjusted to zero.3. Faulty/bad Load Cell(s).	<ol style="list-style-type: none">1. Check and alter per the Instrument Service Manual.2. Zero the instrument according to normal operation procedures.3. Test and replace the Load Cell(s) as shown in Section 4.2.3.

4.2. SCALE PLATFORM TROUBLESHOOTING

Except for severe structural damages, most Platform Assembly problems can be traced to the following causes.

- Material under or around the Platform.
- Broken Load Cell receiver cups..
- Faulty Load Cells.



4.2.1. Scale Platform Testing

1. Inspect the Interface Cable from the Platform to the Instrument for visible breaks or cracks.
2. **ZERO** the Instrument Display.
3. Apply a test load of **25% of the Load Cell capacity** to one corner.
 - The Instrument should display a weight reading within 0.1% of the applied weight, or One Instrument Division, whichever is greater.
4. Repeat Step 3 for all the corners, placing the same Test Load on each corner.

4.2.2. Load Cell Testing

When corners do not match the correct tolerances, unsolder each Load Cell Cable, then test each Load Cell for the settings on the following chart.

TEST	READING	REMARKS
Green to Black (Input)	1106 Ohms (+5 / -2 Ohms)	Input Resistance
Red to White (Output)	1000 Ohms (+5 / -2 Ohms)	Output / Bridge Resistance
Yellow (Shield) to Load Cell Case	More than 1,000 megohms	Insulation Resistance
Input and Output Leads to Shield		
Input and Output Leads to Case		

4.2.3. Load Cell Replacement Steps

1. Cycle-down the power to the indicator, then unplug the unit.
2. Remove the platform and junction box access covers.
3. Loosen the gland bushing, and tie a string or wire to the end of the cable to act as a pull wire.
4. Place wire markers on the cable ends.
 - Masking tape is an effective alternative
5. Disconnect the faulty load cells wires from the terminal block.
6. Lift the platform end with a forklift or heavy pry bar, using wood blocks for safety.
7. Remove the load cell, pulling the cable through the scale while leaving the pull string/wire in the scale.
8. Remove the defective load cell from the receiver cups , then install the new load cell.
 - Use a lubricant on the O-rings.
9. Disconnect the pull string/wire from the defective load cell's cable, then attach to the replacement load cell's cable end.
10. Pull the cable from the new cell through to the junction box.
11. Lower the scale to the surface removing the safety blocks.
12. Distribute the scale's weight evenly on all four (4) load cells..
13. Connect the load cell wires into the junction box, then tighten the box gland bushing(s).
14. Replace the platform access cover.

Section 5: Parts

5.1. PARTS LISTS #107979 – 5' X 5' X 8", 20K

ITEM	QTY	PART No.	DESCRIPTION
1	1	107972	PLATFORM WELDMENT, X-TREME
2	1	107978	FRAME WELDMENT
3	2	107701	BASE PLATE W/LOWER CUP
4	2	107702	BASE PLATE W/LOWER CUP
5	4	105718	UPPER CUP W/O ANTI-ROTATION
6	1	67171M	J- BOX ASSY. SS
7	4	108120	3 1/2" RC L/C /, 15k
8	12	61743	CLAMP BAR
9	4	54555	3/4"-10 x 3 1/2" HEX HEAD CAP SCREW
10	16	54264	3/4" HEX NUT
11	1	83861	WEDGE ANCHOR BOX
12			STICKER, FAIRBANKS SCALES
13	13	54406	1/2"-13 x 3/4" LG FLAT HEAD SOCKET
14	4	54233	3/4" FLAT WASHER
15	4	107797	SHIM, .01 x 1 1/2" ID x 2 1/8" OD
16	4	107798	SHIM, .03 x 1 1/2" ID x 2 1/8" OD
17	4	72967	FULL THD BOLT, 3/4"- 10 x 5" LG
18	4	54218	FULL THD BOLT, 3/4"- 10 x 3" LG

5.2. PARTS LIST #106966 – 6' X 8' X 8", 40K

ITEM	QTY	PART No.	DESCRIPTION
1	1	106975	PLATFORM WELDMENT, X-TREME
2	1	107976	FRAME WELDMENT
3	2	107701	BASE PLATE W/LOWER CUP
4	2	107702	BASE PLATE W/LOWER CUP
5	4	105718	UPPER CUP W/O ANTI-ROTATION
6	1	67171M	J- BOX ASSY. SS
7	4	108121	3 1/2" RC L/C /, 30k
8	12	61743	CLAMP BAR
9	4	54555	3/4"-10 x 3 1/2" HEX HEAD CAP SCREW
10	16	54264	3/4" HEX NUT
11	1	83861	WEDGE ANCHOR BOX
12			STICKER, FAIRBANKS SCALES
13	13	66979	1/2"-13 x 1" LG FLAT HEAD SOCKET
14	4	54233	3/4" FLAT WASHER
15	4	107797	SHIM, .01 x 1 1/2" ID x 2 1/8" OD
16	4	107798	SHIM, .03 x 1 1/2" ID x 2 1/8" OD
17	4	72967	FULL THD BOLT, 3/4"- 10 x 5" LG
18	4	54218	FULL THD BOLT, 3/4"- 10 x 3" LG

5.4. PARTS DIAGRAM

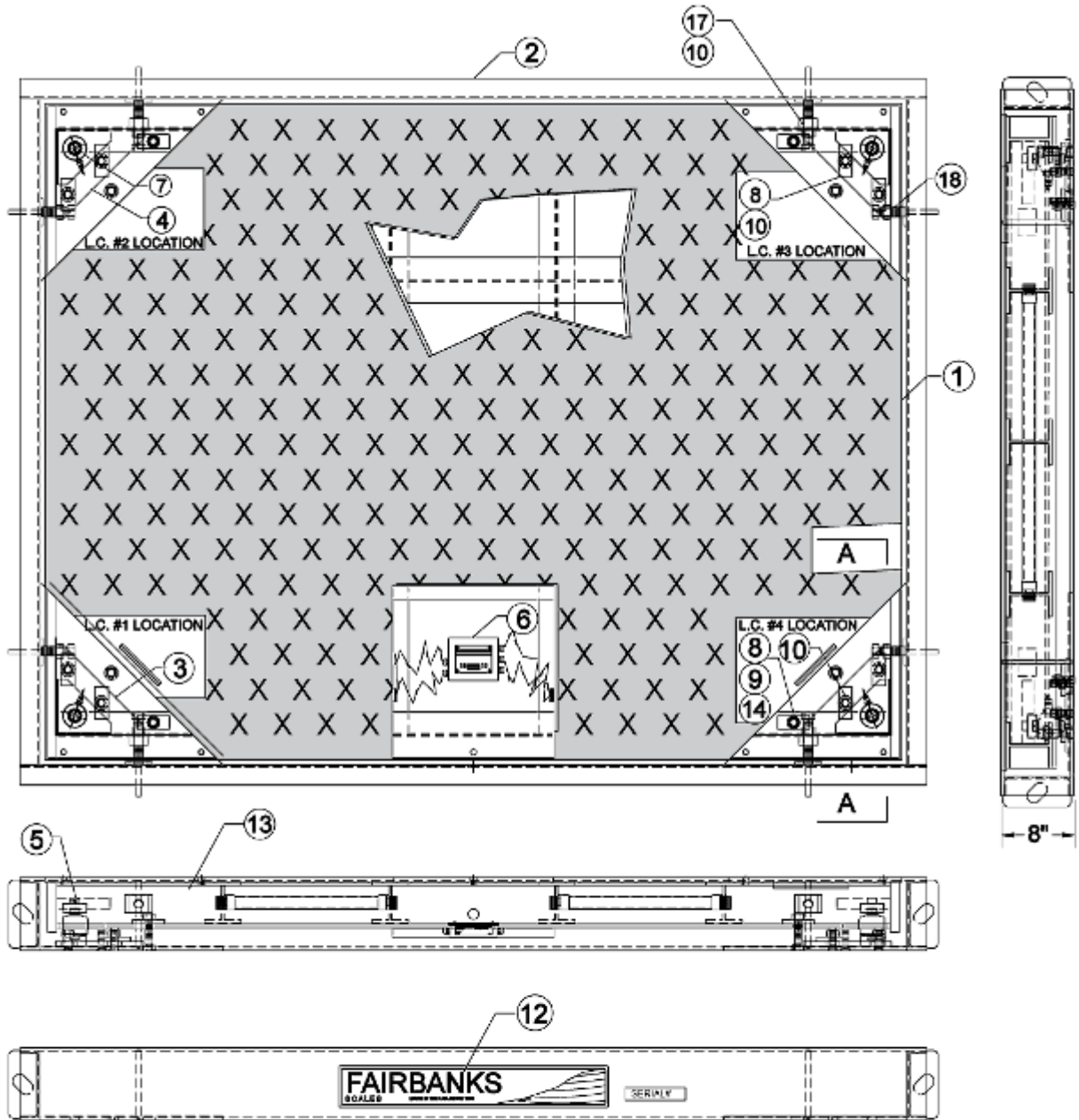

Aegis X-treme Duty
Floor Scale
51206-4

5.5. ACCESSORY PART NUMBERS

5.5.1. Aegis Xtreme-Duty Ramp Assembly

Part No.	Description
108413	Aegis Xtreme-Duty Ramp Assembly, 4' ramp
107988	Aegis Xtreme-Duty Ramp Assembly, 5' ramp
107307	Aegis Xtreme-Duty Ramp Assembly, 6' ramp
108415	Aegis Xtreme-Duty Ramp Assembly, 8' ramp

5.5.2. Aegis Xtreme-Duty Pit Frame Assembly

Part No.	Description
108440	Aegis Xtreme-Duty Pit Frame, 4' x 4'
108441	Aegis Xtreme-Duty Pit Frame, 4' x 8'
108442	Aegis Xtreme-Duty Pit Frame, 5' x 5'
108443	Aegis Xtreme-Duty Pit Frame, 6' x 6'
108444	Aegis Xtreme-Duty Pit Frame, 6' x 8'

5.5.3. Mild Steel Stand-alone Instrument Pillar

Part No.	Description
28396	Stand-alone Pillar Assembly, Mild Steel
28392	MS Base Plate
28561	MS Base Plate Support
28760	MS Top Plate Assy
27787	MS Pillar Weldment
12777	Foot

5.3. Platform Model Matrix

PRODUCT NO.	SIZE	CAPACITY
108400	4' x 4'	20,000 lbs
108401	4' x 8'	20,000 lbs
107979	5' x 5'	20,000 lbs
108402	6' x 6'	20,000 lbs
108403	6' x 8'	20,000 lbs
108404	6' x 6'	40,000 lbs
106966	6' x 8'	40,000 lbs
108409	6' x 6'	60,000 lbs
108410	6' x 8'	60,000 lbs



Manufactured by Fairbanks Scale, Inc.
821 Locust
Kansas City, MO 64106

www.fairbanks.com

Aegis Xtreme-Duty Floor Scale

INSTALLATION MANUAL
DOCUMENT 51206